

NOT SHOWN:
 CONSOLE IN CAB
 EMERG. ENGINE SHUT DOWN
 KUSSMAUL BATT. CONDITIONER
 REFLECTIVE STRIPING

BLACK END TARP OVER SPEED LAYS

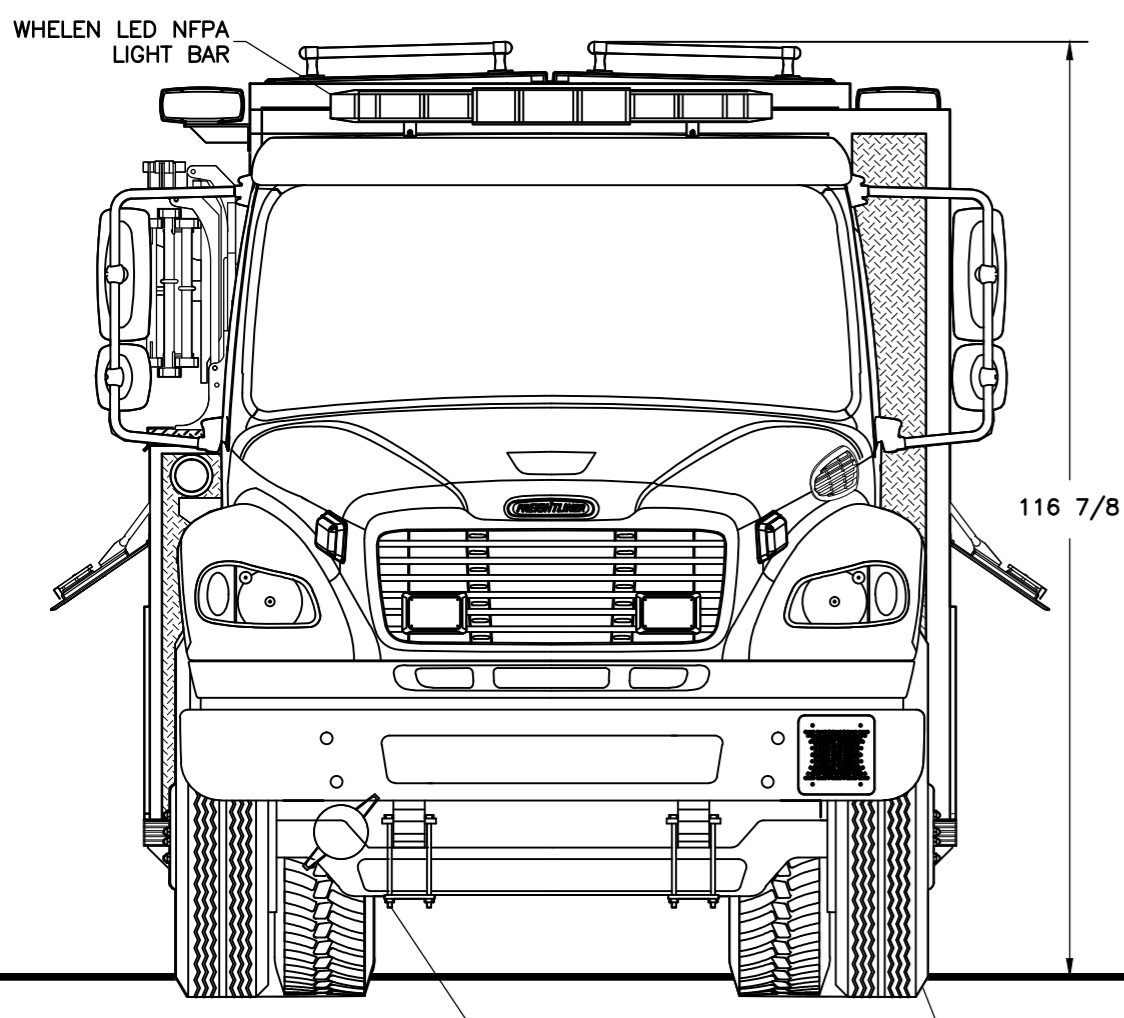

FRONT

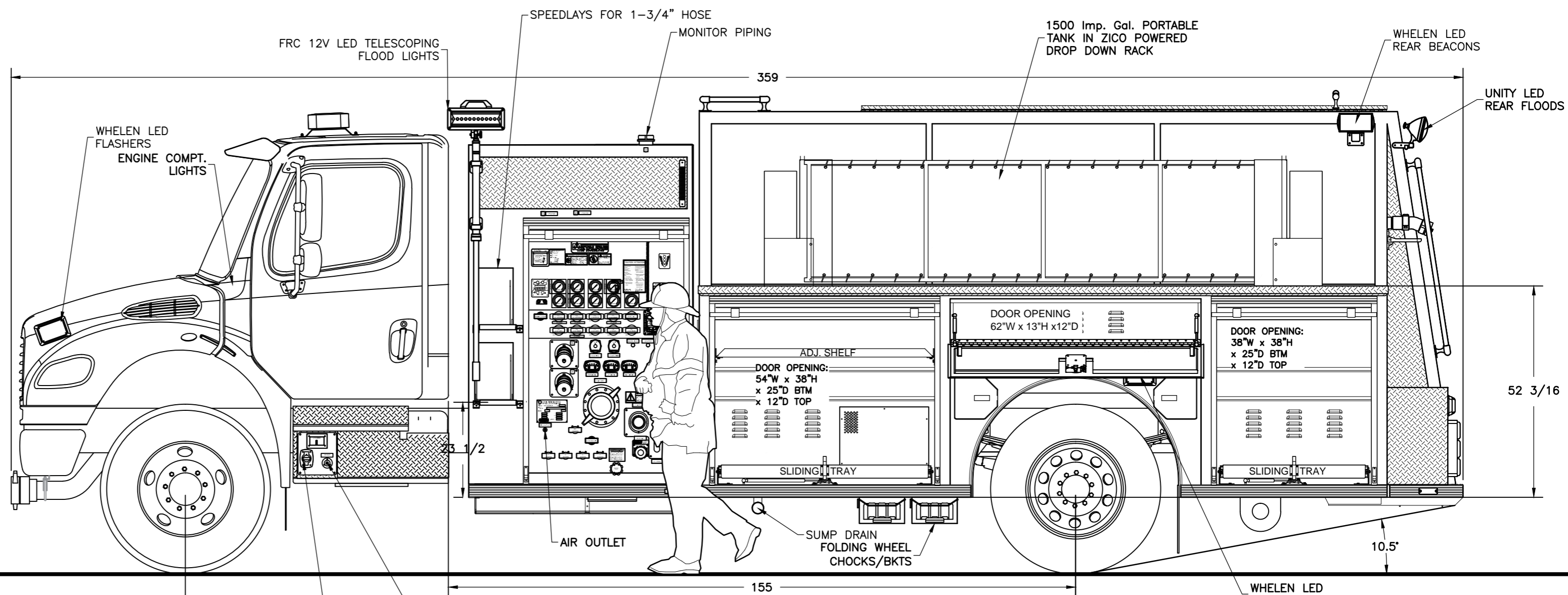

LEFT SIDE

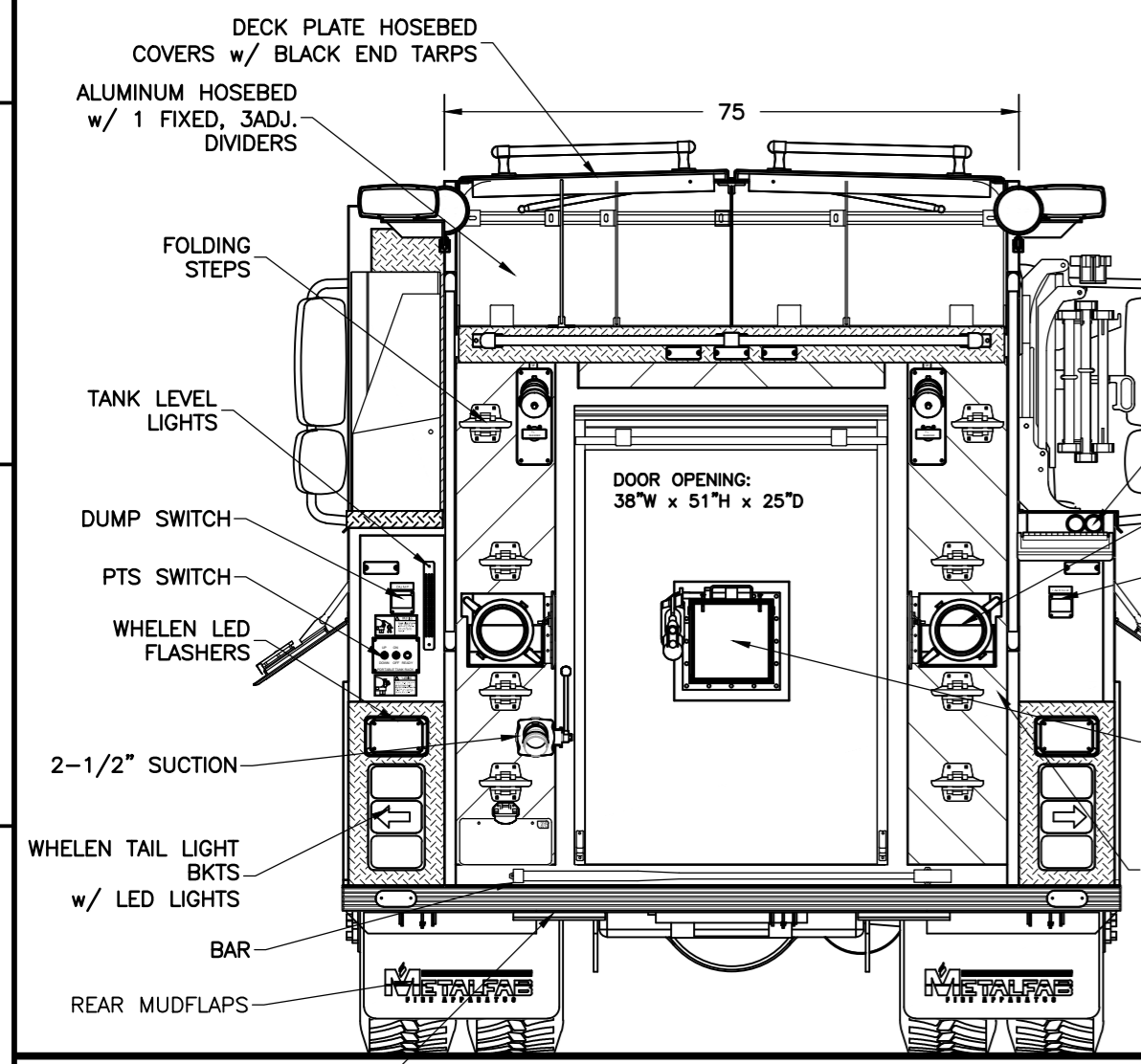

REAR

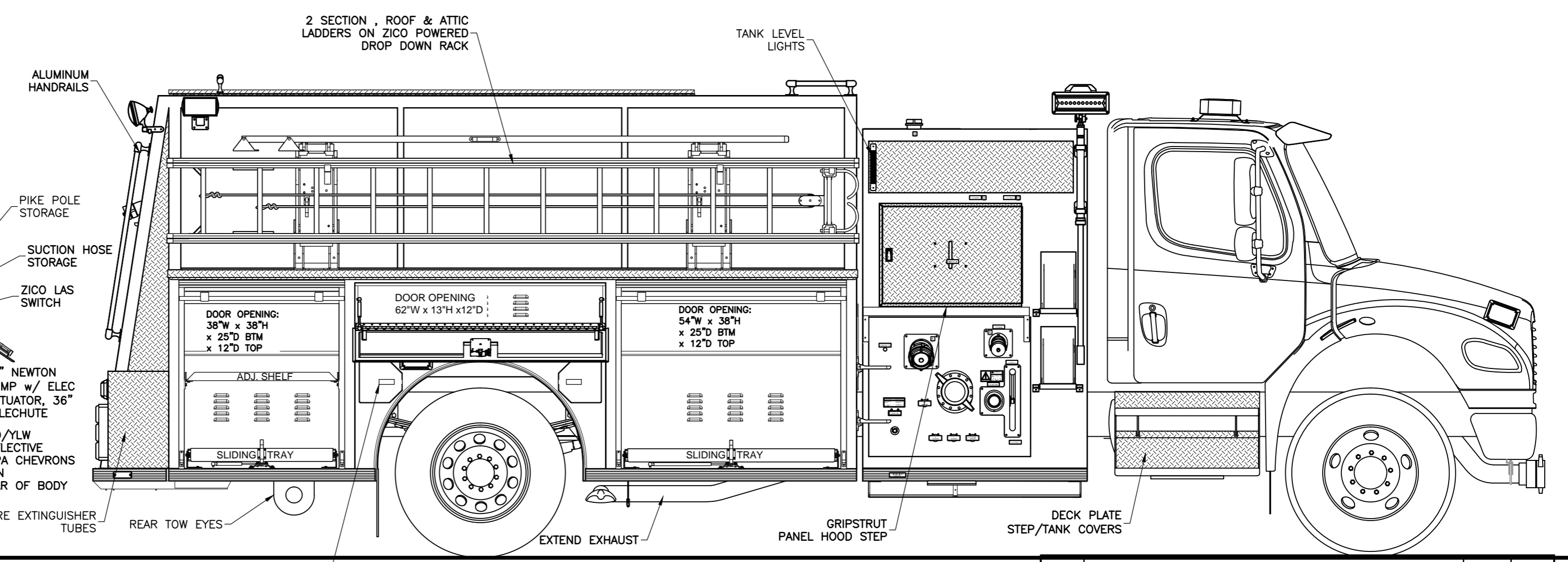

RIGHT SIDE

CHASSIS: FREIGHTLINER M2 106 2 DOOR
 PUMP: WATEROUS CS 1050 IGPM
 TANK: 1000 Imp. Gal. POLYPROPYLENE
 2 - 20 Imp. Gal. FOAM CELLS
 FOAM: HYPRO FOAMPRO 2001 DUAL TANK

SUCTION: 1 - 6" LEFT (ELEC GATE)
 1 - 6" RIGHT (ELEC. GATE)
 1 - 6" FRONT (4" PIPE, ELEC GATE)
 1 - 4" TANK TO PUMP
 1 - 2 1/2" LEFT
 1 - 2 1/2" RIGHT
 1 - 2 1/2" REAR

DISCHARGES: 1 - 4" RIGHT
 1 - 3" MONITOR
 1 - 3" TANK FILL
 2 - 2 1/2" LEFT (1 FOAM)
 1 - 2 1/2" RIGHT
 2 - 2 1/2" REAR (FOAM)
 2 - 1 1/2" SPEEDLAYS (FOAM)

-ALL ALUMINUM CONSTRUCTION - ALL DIMENSIONS ARE IN INCHES & APPROXIMATE

2	REVISIONS PER MARK-UPS AUG 25 / 15	JOL	9/12/15
1	ADDED SPEEDLAYS	RM	08/12/15
0	FIRST ISSUE		
REV	DESCRIPTION	APVD BY	DATE

MEMRAMCOOK FIRE DEPARTMENT		TITLE GENERAL ARRANGEMENT	
JOB No.	18586		
DRAWN BY	T CULLINS		
DATE	06-05-15		
METALFAB LTD. 847 CENTRAL ST. CENTREVILLE NB. CANADA E7K 2E8		DRAWING NO.	FT-10739R1
		REV	2