

8

7

6

5

4

3

2

1

NOT SHOWN:  
CONSOLE IN CAB

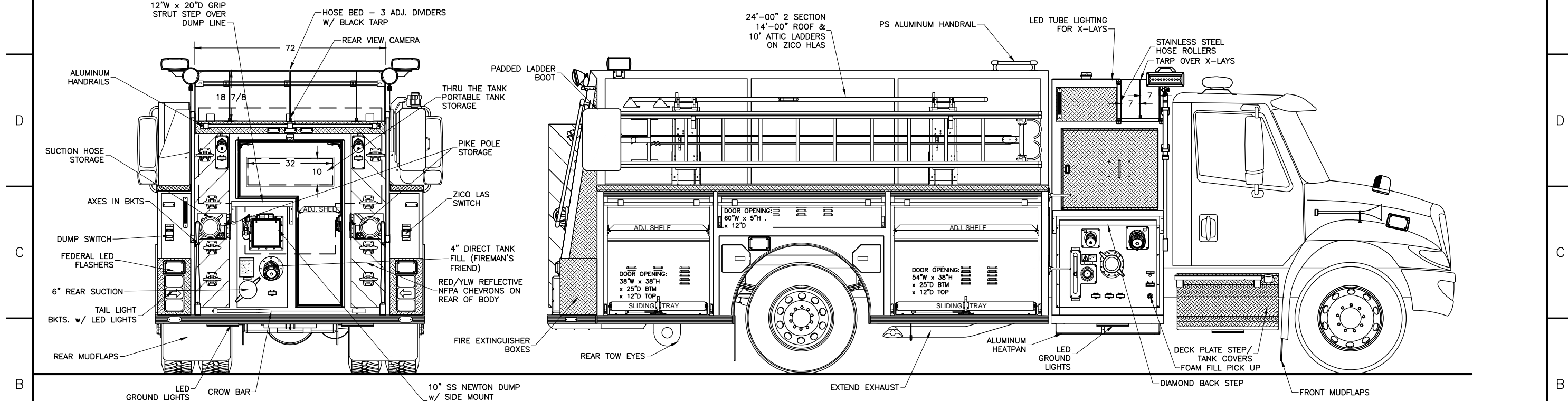
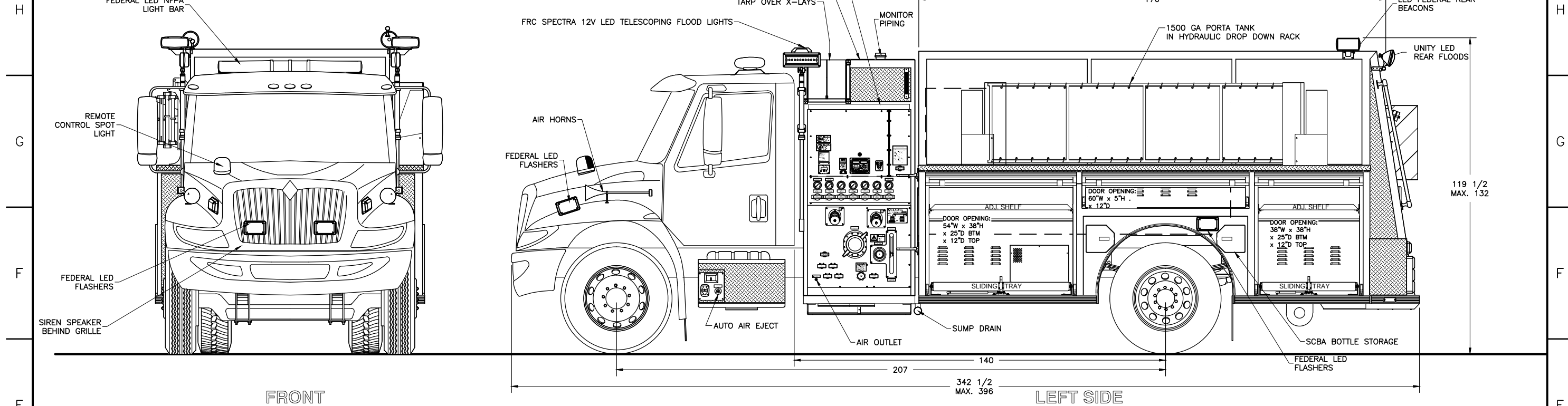

1	UPD'D FROM FT-10572	06/01/2015
REV	DESCRIPTION	APVD BY DATE
REVISIONS		

CHASSIS: INTERNATIONAL 4400	SUCTION: 1 - 6" REAR (5" PIPE, ELEC MIV)	DISCHARGES: 1 - 4" RIGHT	2 - 1 1/2" CROSSLAYS (FOAM)
PUMP: HALE QFLO 1050 IGPM	1L, 1R - 6" (ELEC MIV)	1 - 3" MONITOR	
TANK: 1000 Imp. Gal, POLYPROPYLENE	1L, 1R - 2 1/2"	2 - 2 1/2" LEFT	
1 - 20 Imp. Gal. FOAM CELL	1 - 4" TANK TO PUMP	1 - 2 1/2" RIGHT (FOAM)	
FOAM: HYPRO FOAMPRO 2001 SINGLE		2 - 2 1/2" REAR (FOAM) RS ONLY	
		1 - 3" TANK FILL	

<b>UPHAM FIRE DEPARTMENT</b>		TITLE	<b>GENERAL ARRANGEMENT</b>
JOB No.	18242		
DRAWN BY	J. O'LEARY		
DATE	6-1-15		

-ALL ALUMINUM CONSTRUCTION - ALL DIMENSIONS ARE IN INCHES & APPROXIMATE

8

7

6

5

4

3

2

1

DRAWING NO.	FT-10680	REV	1
-------------	----------	-----	---