

NOT SHOWN
 4 - 600 lbs Cap. SLIDING TRAYS
 8 - ADJ. SHELVES
 CONSOLE IN CAB
 1 SLIDING VERTICAL TOOL BOARD
 1 - SWING OUT TOOL BOARD

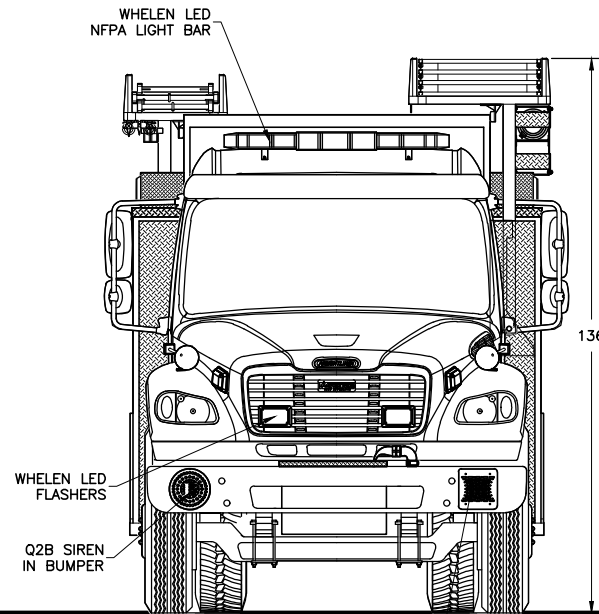

FRONT

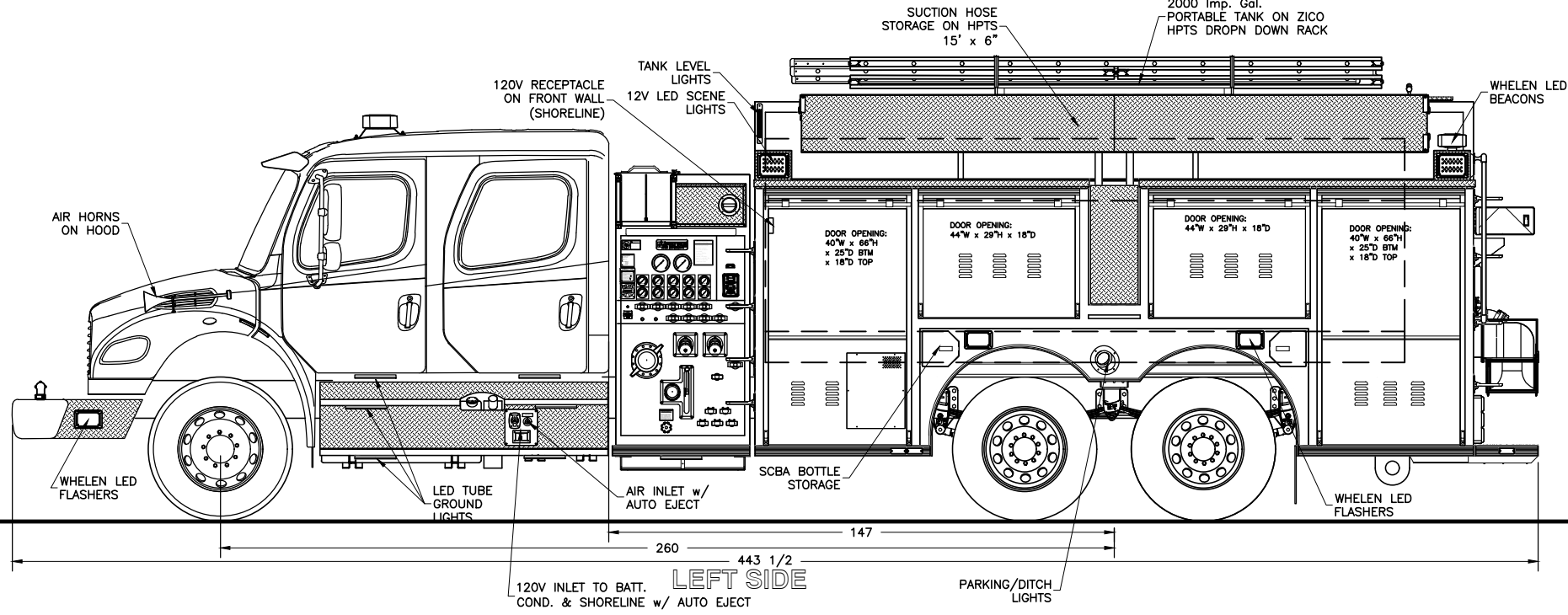

LEFT SIDE

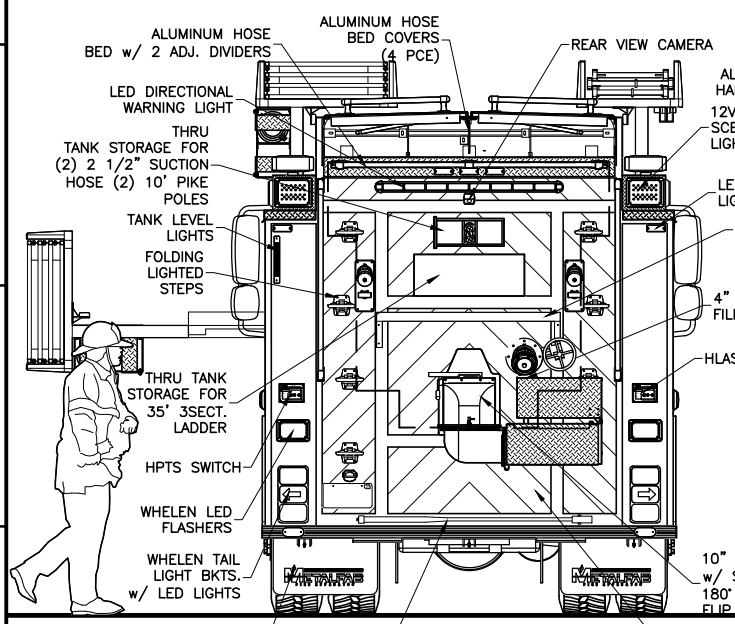

REAR

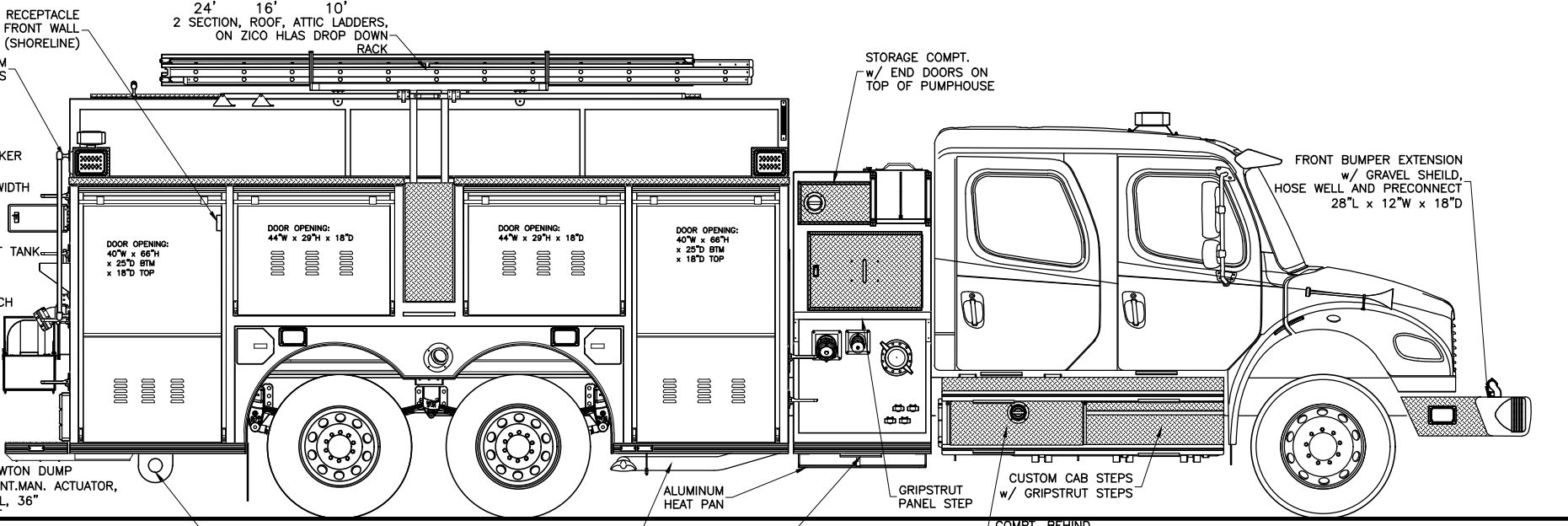

RIGHT SIDE

CHASSIS: FREIGHTLINER M2 106 4 DOOR
 PUMP: WATEROUS CXVA 1050 IGPM
 TANK: 2000 Imp. Gal. POLYPROPYLENE
 1 - 25 Imp. Gal. FOAM CELL
 FOAM: HYPRO FOAM PRO 2001

SUCTION: 1 - 6" LEFT
 1 - 6" RIGHT
 1 - 3" TANK TO PUMP
 1 - 2 1/2" LEFT

DISCHARGES: 1 - 4" RIGHT
 1 - 3" MONITOR (CAPPED, 1 - 2" TANK FILL
 FLUSH w/PUMPHOUSE STORAGE FLOOR)
 2 - 2 1/2" LEFT
 1 - 2 1/2" RIGHT
 1 - 2 1/2" REAR (FOAM)

1 - 2 1/2" HOSEBED
 2 - 1 1/2" CROSSLAYS (FNT FOAM)
 1 - 1 1/2" TRASH LINE (FOAM)

REV	DESCRIPTION	APPROVED BY	DATE
D	RELOCATE SHORELINES / ADDED NOTES		09-08-16
C	GENERAL REV		05-28-16
B	SHORTENED WHEEL BASE		
A	UPDATE TO 1/0		03-16-16
0	FIRST ISSUE		

MIDDLESEX CENTER
 FIRE DEPARTMENT
 JOB No. PROPOSAL
 DRAWN BY T CULLINS
 DATE 02-08-16
 METALFAB LTD.
 847 CENTRAL ST. CENTREVILLE
 NB. CANADA E7K 2E8

TITLE GENERAL ARRANGEMENT

DRAWING NO. FT-10801

-ALL ALUMINUM CONSTRUCTION - ALL DIMENSIONS ARE IN INCHES & APPROXIMATE