

CHASSIS: FREIGHTLINER M2 106 2 DOOR  
 PUMP: WATEROUS CS SPLIT SHAFT 1050 IGPM  
 TANK: 1000 Imp. Gal. POLYPROPYLENE  
 1 - 30 Imp. Gal. FOAM CELL  
 FOAM: FOAMPRO 2001

SUCTION: 1 - 6" LEFT (ELEC. GATE)  
 1 - 6" RIGHT (NO GATE)  
 1 - 3" TANK TO PUMP  
 1 - 2 1/2" LEFT  
 1 - 2 1/2" RIGHT

DISCHARGES: 1 - 4" RIGHT (3" VALVE)  
 1 - 3" MONITOR  
 2 - 2 1/2" LEFT  
 1 - 2 1/2" RIGHT  
 1 - 2 1/2" REAR (FOAM)

1 - 2" TANK FILL  
 2 - 1 1/2" SPEEDLAYS (FOAM)

REV	DESCRIPTION	BY	DATE
0	FIRST ISSUE		
REVISIONS			
MARYSTOWN FIRE DEPARTMENT		TITLE GENERAL ARRANGEMENT	
JOB No.	22918		
DRAWN BY	HDS		
DATE	MARCH 13, 2024		
METALFAB LTD. 847 CENTRAL ST. CENTREVILLE NB. CANADA E7K 2E8			
DRAWING NO. 22918-19 SHT 1 OF 3		REV 0	

-ALL ALUMINUM CONSTRUCTION - ALL DIMENSIONS ARE IN INCHES & APPROXIMATE

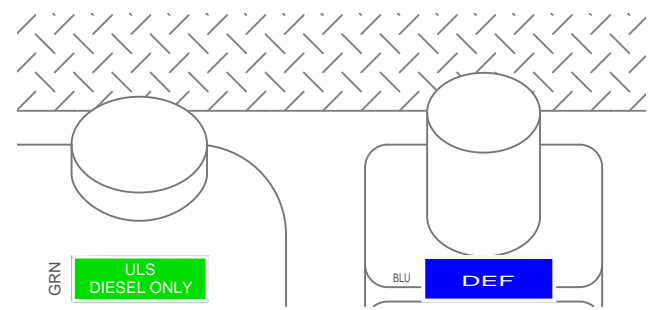
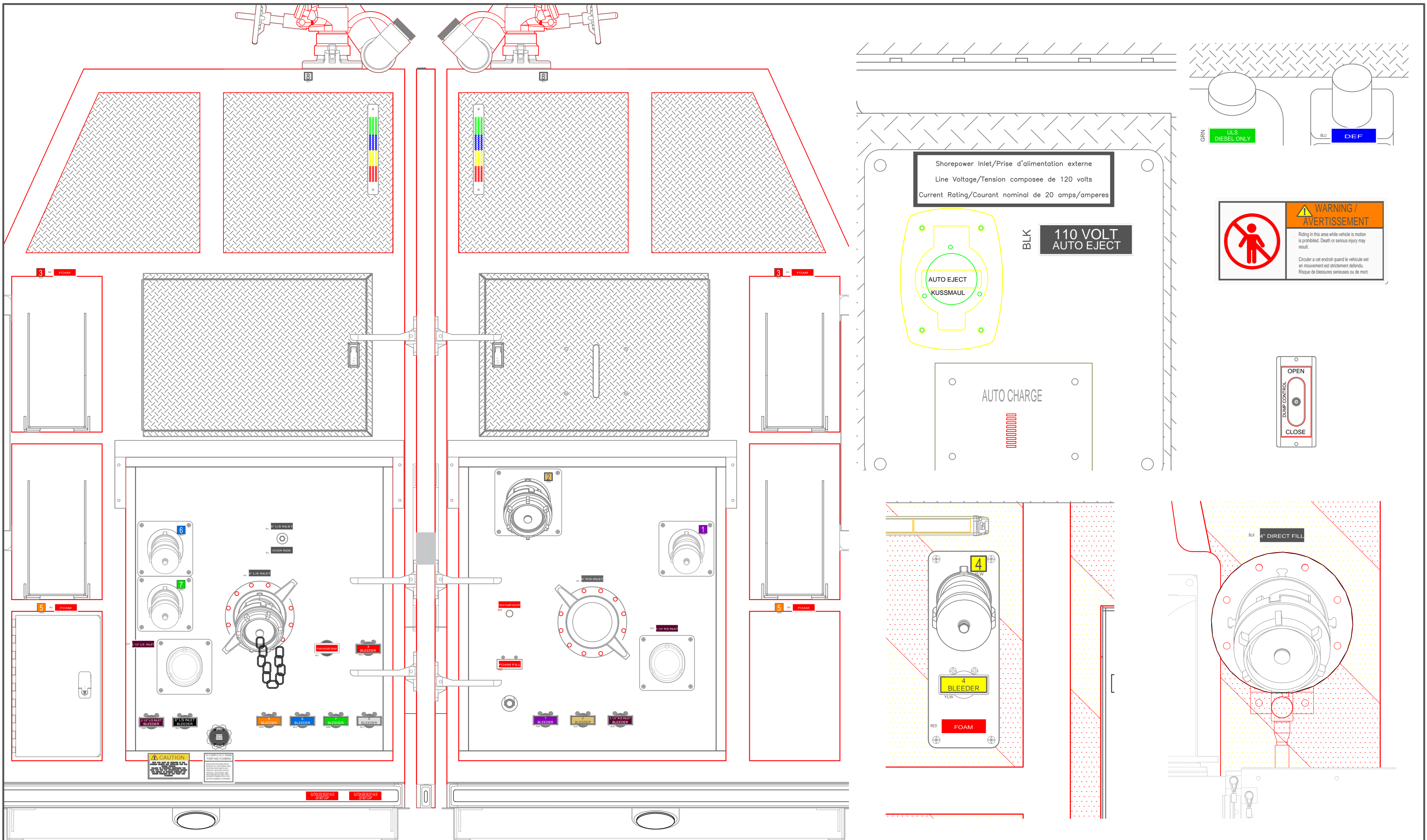

**WARNING / AVERTISSEMENT**  
 Riding in this area while vehicle is motion is prohibited. Death or serious injury may result.  
 Circuler a cet endroit quand le vehicule est en mouvement est strictement defendu. Risque de blessures serieuses ou de mort.

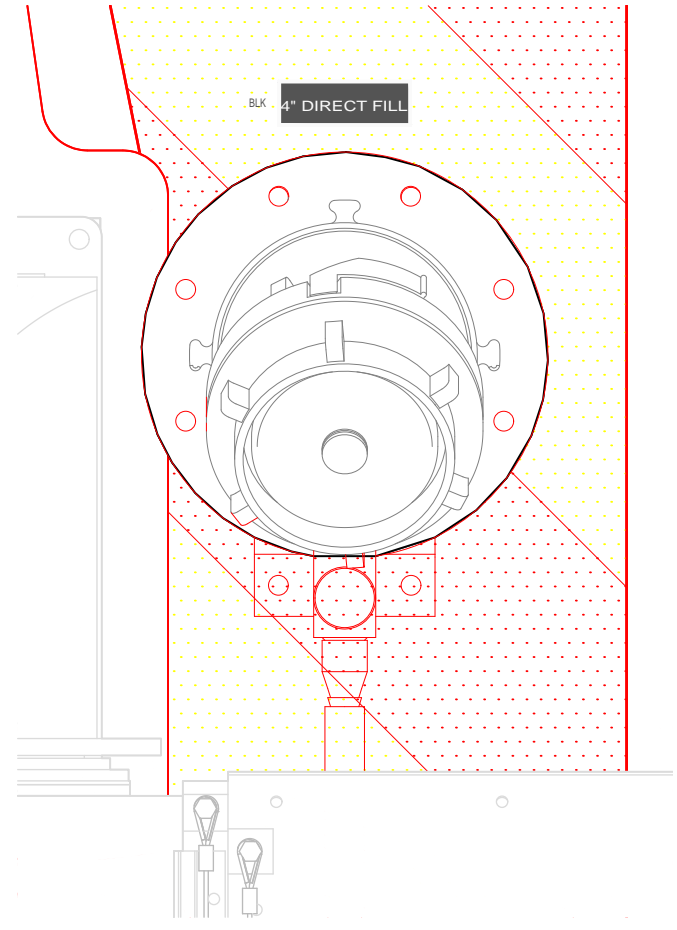
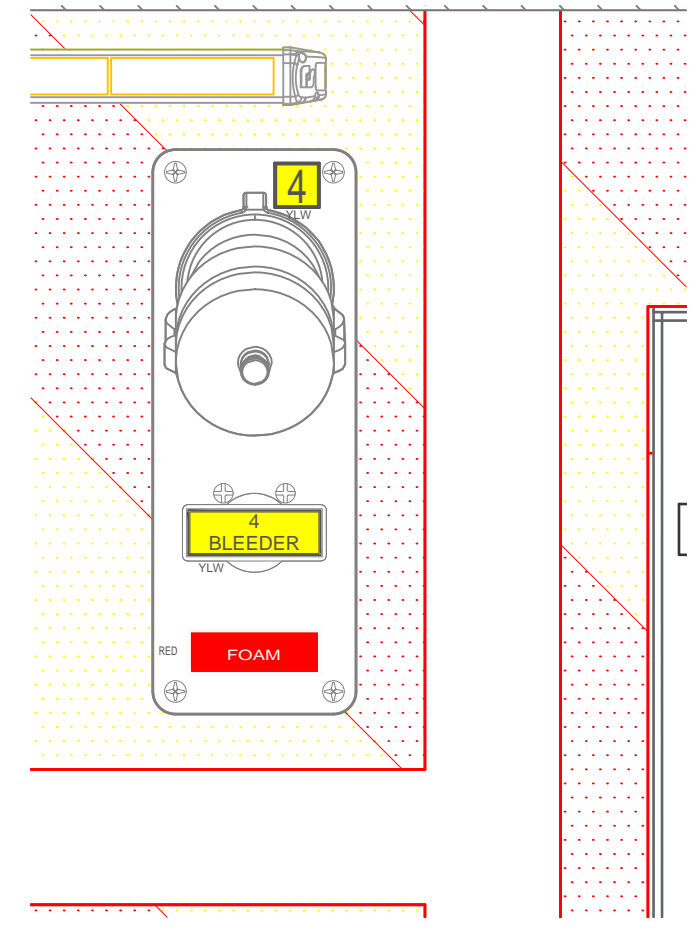
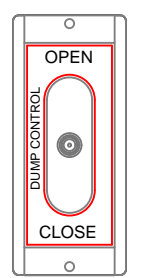

REV	DESCRIPTION	BY	DATE
0	FIRST ISSUE		

  

REVISIONS	
TITLE	DATE
MARYSTOWN FIRE DEPARTMENT	
JOB No. 22918	
DRAWN BY HDS	
DATE MARCH 13, 2024	
METALFAB LTD.	
847 CENTRAL ST. CENTREVILLE NB. CANADA E7K 2E8	

TITLE	DATE
SIDE PANELS	
<b>METALFAB</b> FIRE TRUCKS	
DRAWING NO. 22918-19 SHT 2 OF 3	
REV 0	

-ALL ALUMINUM CONSTRUCTION - ALL DIMENSIONS ARE IN INCHES & APPROXIMATE

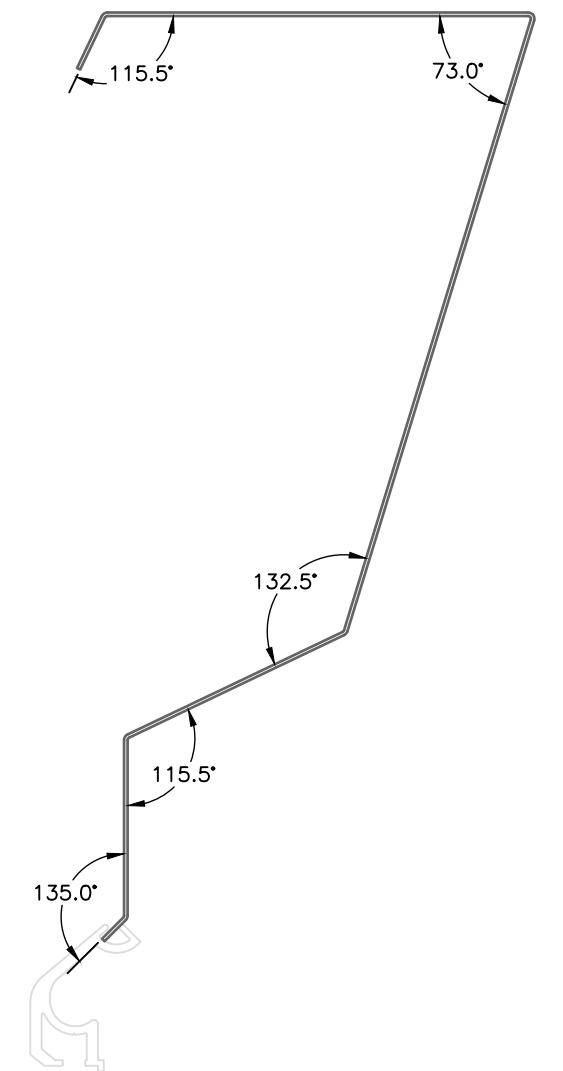
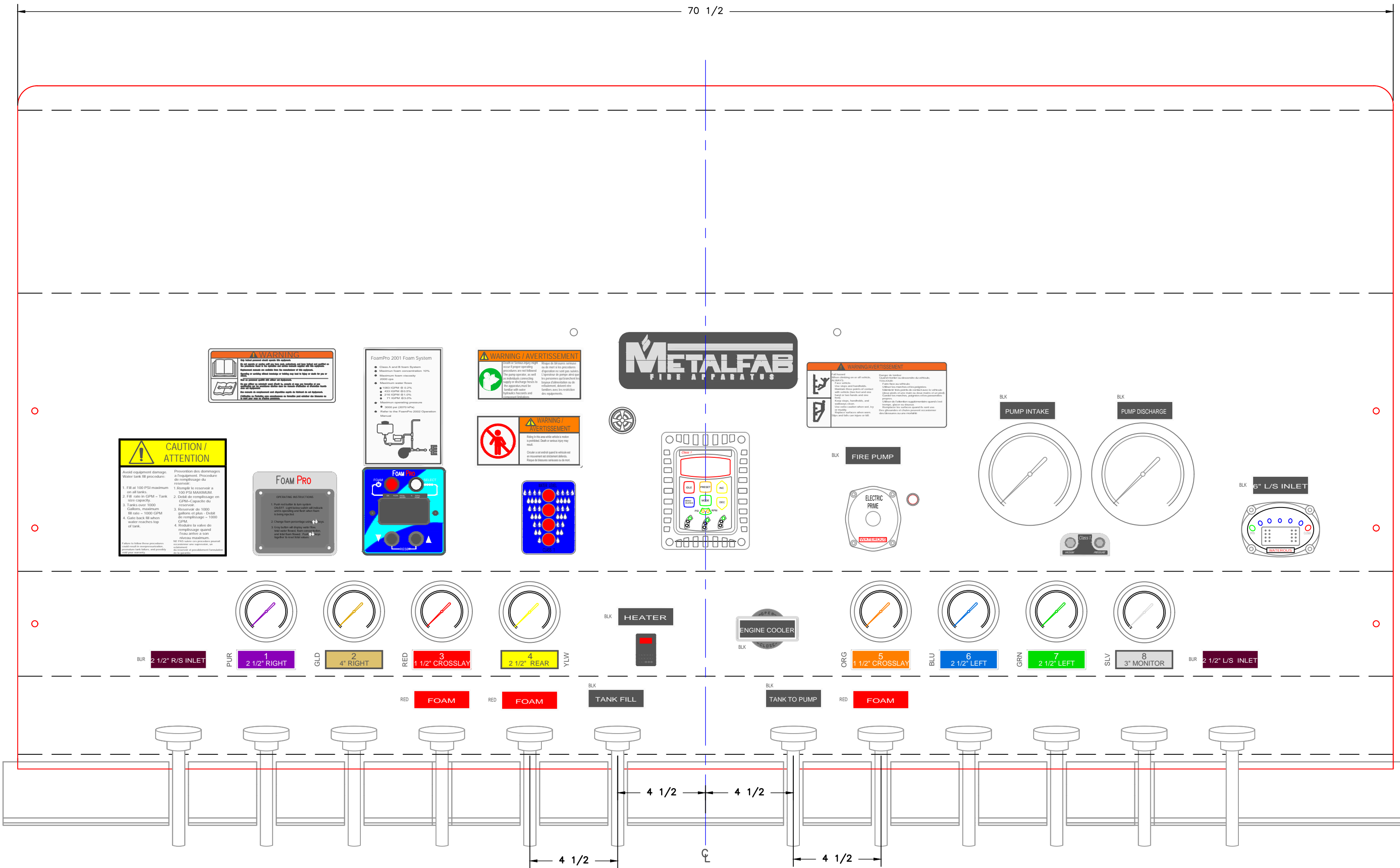

-ALL ALUMINUM CONSTRUCTION - ALL DIMENSIONS ARE IN INCHES & APPROXIMATE

REV	DESCRIPTION	BY	DATE
0	FIRST ISSUE		
REVISIONS			

MARYSTOWN FIRE DEPARTMENT		TITLE OPERATOR'S PANEL	
JOB No.	22918		
DRAWN BY	HDS		
DATE	MARCH 13, 2024		
METALFAB LTD. 847 CENTRAL ST. CENTREVILLE NB. CANADA E7K 2E8		DRAWING NO.	22918-19 SHT 3 OF 3
		REV	0