

CHASSIS: INTERNATIONAL HV607 2 DOOR PUMP: HALE RSD-J 5000 LPM PTO DRIVE TANK: 1500 Imp. Gal. POLYPROPYLENE FOAM: N/A		SUCTION: 1 - 6" LEFT (ELEC. GATE) 1 - 6" RIGHT (ELEC. GATE) 1 - 3" TANK TO PUMP 1 - 2 1/2" LEFT 1 - 2 1/2" RIGHT		DISCHARGES: 1 - 4" RIGHT (3" PIPING) 1 - 2 1/2" RIGHT 1 - 2 1/2" LEFT 1 - 2 1/2" CROSSLAY w 2 1/2" TO 1 1/2" ADAPTER (REARWARD LOCATION)		1 - 2" TANK FILL 2 - 1 1/2" CROSSLAY (FORWARD LOCATION)		<table border="1"> <tr> <th>REV</th> <th>DESCRIPTION</th> <th>BY</th> <th>DATE</th> </tr> <tr> <td>0</td> <td>FIRST ISSUE</td> <td></td> <td></td> </tr> </table>		REV	DESCRIPTION	BY	DATE	0	FIRST ISSUE			THE CORP. OF THE TOWNSHIP OF UXBRIDGE JOB No. 22694 DRAWN BY HDS DATE JUNE 11, 2024 METALFAB LTD. 847 CENTRAL ST. CENTREVILLE NB. CANADA E7K 2E8		TITLE GENERAL ARRANGEMENT  DRAWING NO. 22694-19 PG 1 OF 3 REV 0	
REV	DESCRIPTION	BY	DATE																		
0	FIRST ISSUE																				

-ALL ALUMINUM CONSTRUCTION - ALL DIMENSIONS ARE IN INCHES & APPROXIMATE

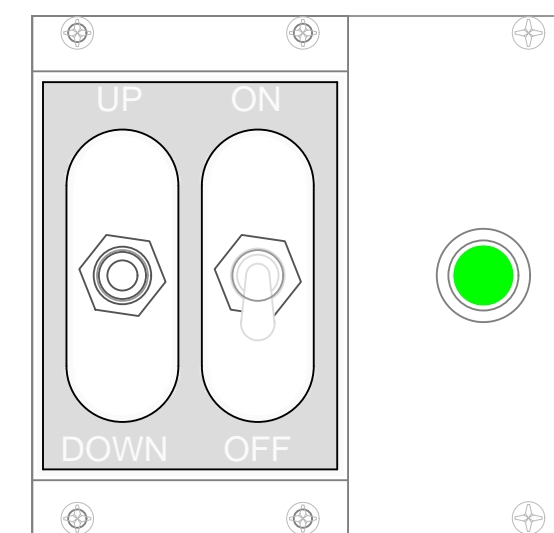

REAR LEFT SIDE

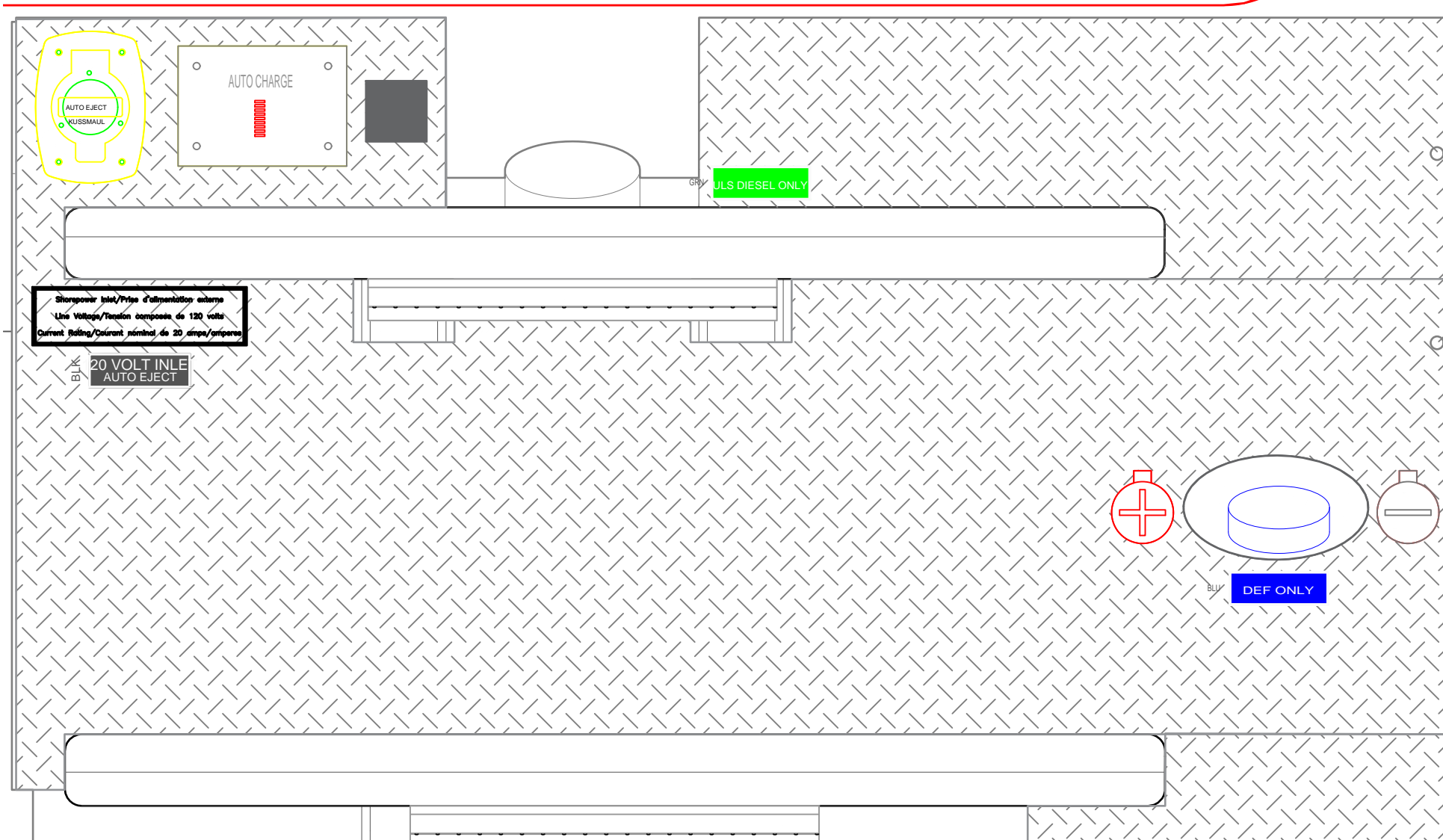
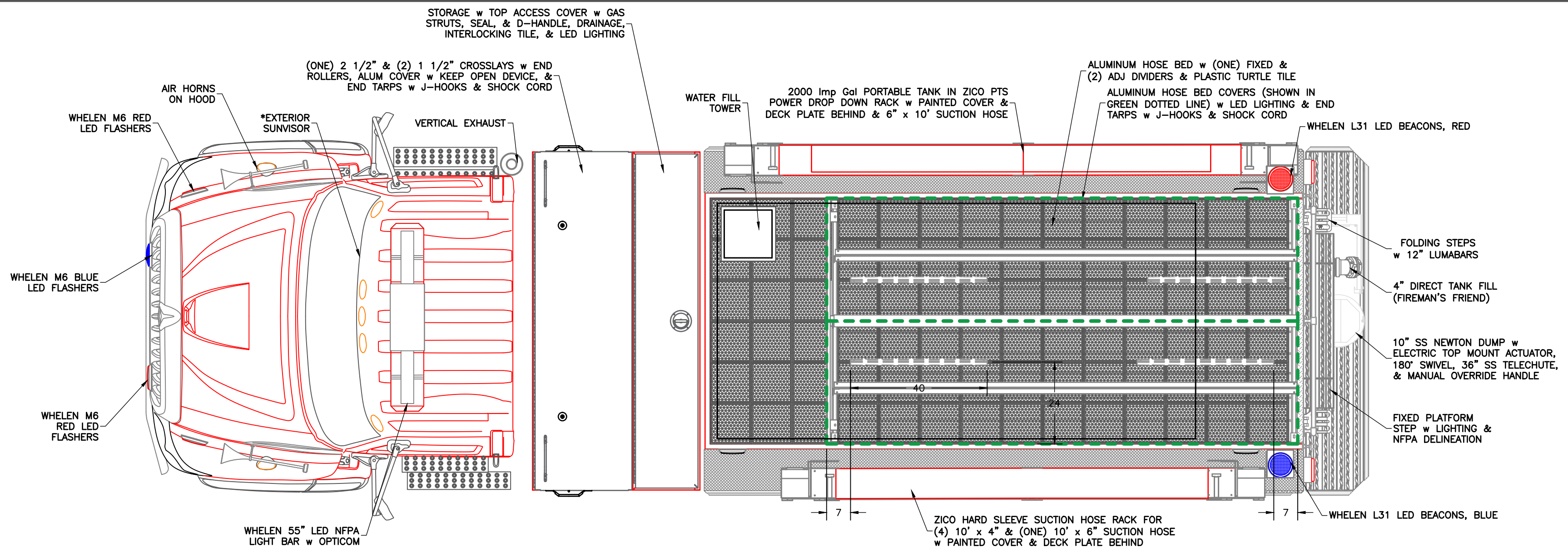
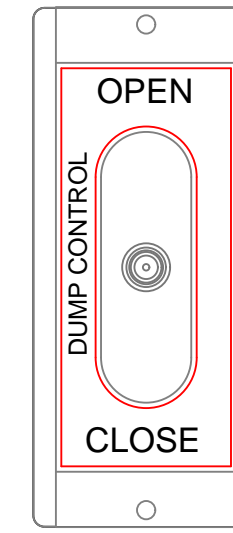
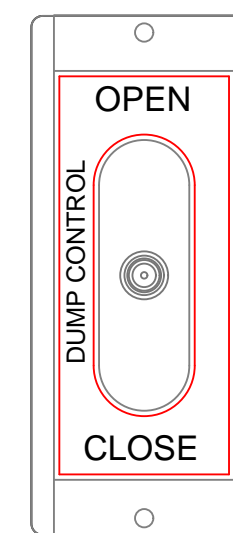

REAR RIGHT SIDE

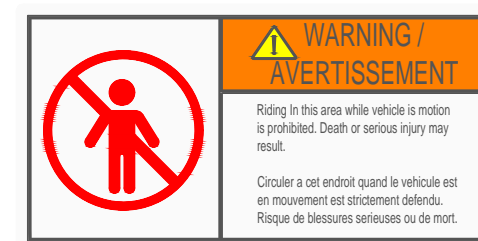
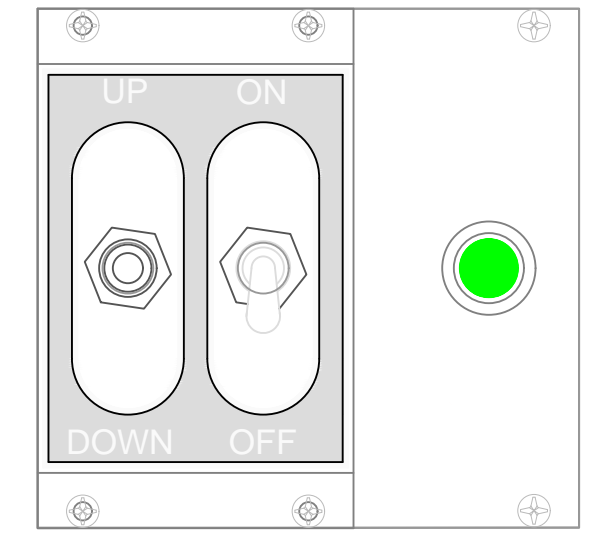

- BLK 8' PIKE POLE
- BLK 12' PIKE POLE
- BLK 6' COLORADO HOOK

-ALL ALUMINUM CONSTRUCTION - ALL DIMENSIONS ARE IN INCHES & APPROXIMATE

REV	DESCRIPTION	BY	DATE
0	FIRST ISSUE		
REVISIONS			

THE CORP. OF THE TOWNSHIP OF UXBRIDGE	TITLE TOP VIEW
JOB No. 22694	
DRAWN BY HDS	
DATE JUNE 11, 2024	
METALFAB LTD. 847 CENTRAL ST. CENTREVILLE NB. CANADA E7K 2E8	
DRAWING NO. 22694-19 PG 2 OF 3	
REV 0	

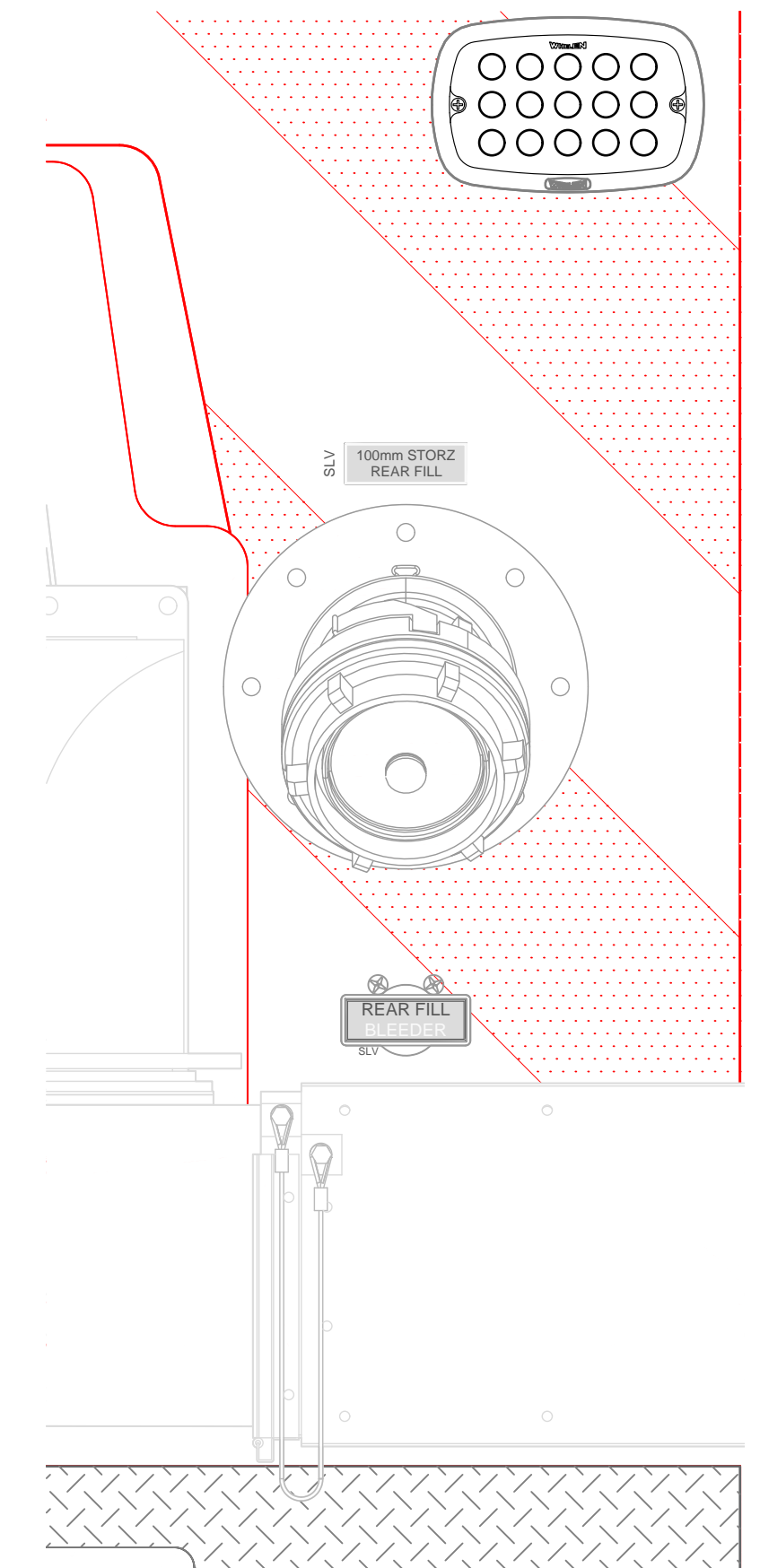
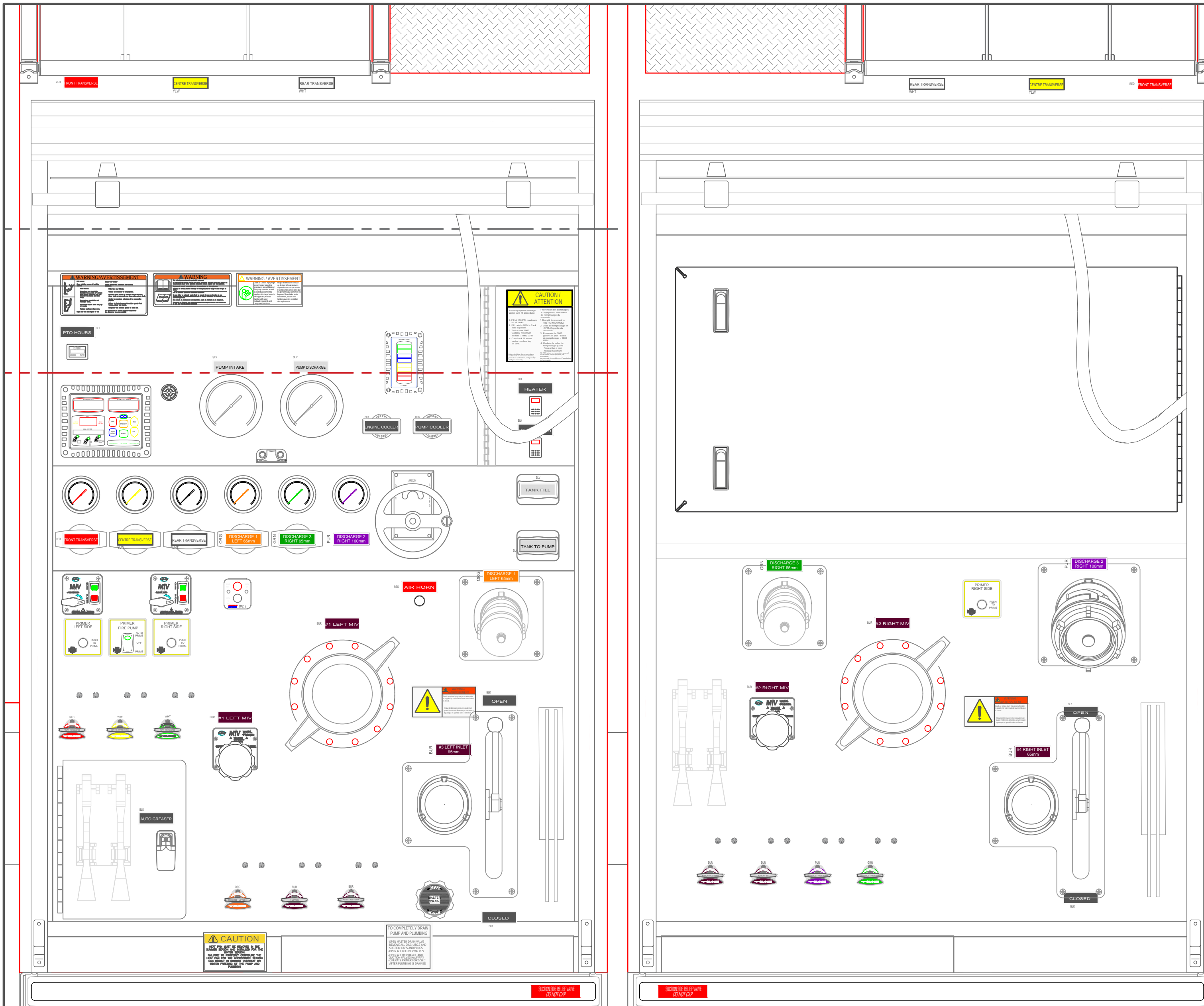

-ALL ALUMINUM CONSTRUCTION - ALL DIMENSIONS ARE IN INCHES & APPROXIMATE

REV	DESCRIPTION	BY	DATE
0	FIRST ISSUE		
REVISIONS			

THE CORP. OF THE TOWNSHIP OF UXBRIDGE JOB No. 22694 DRAWN BY HDS DATE JUNE 11, 2024 METALFAB LTD. 847 CENTRAL ST. CENTREVILLE NB. CANADA E7K 2E8	TITLE OPERATOR'S PANELS  DRAWING NO. 22694-19 PG 3 OF 3 REV 0
---	---

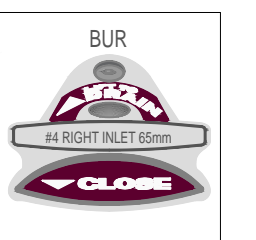
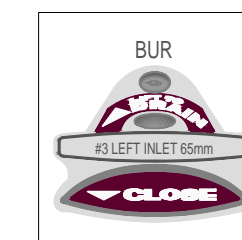
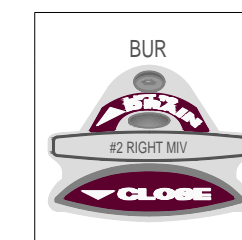
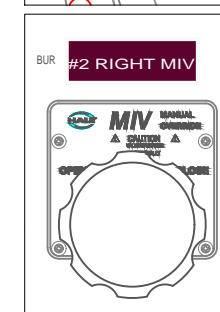
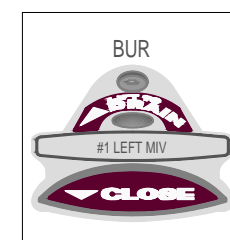
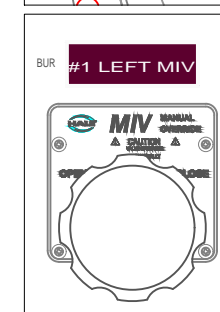
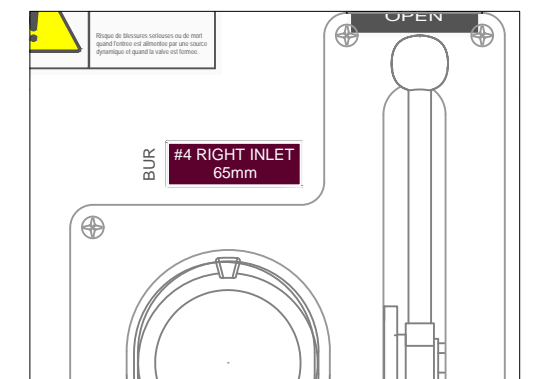
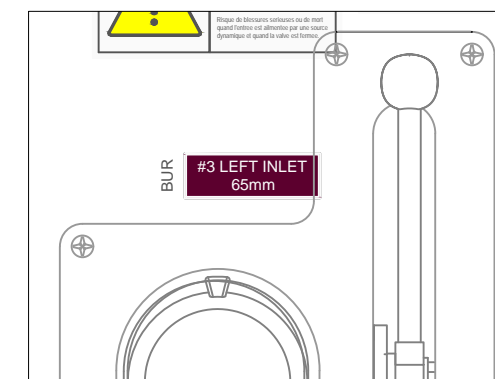
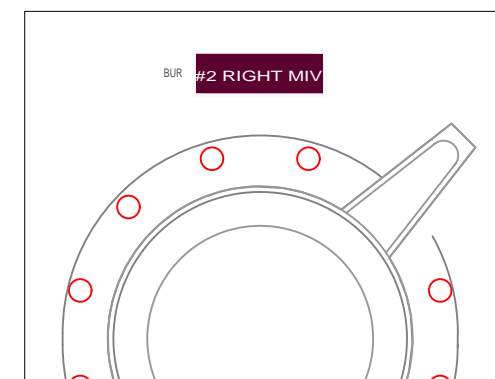
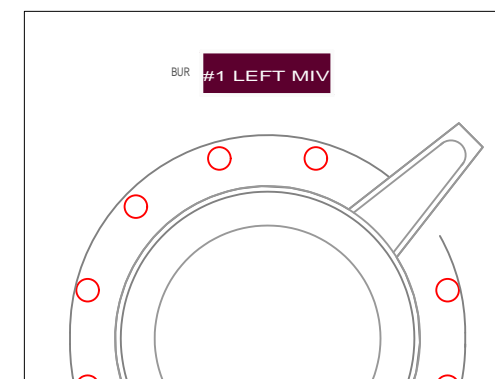
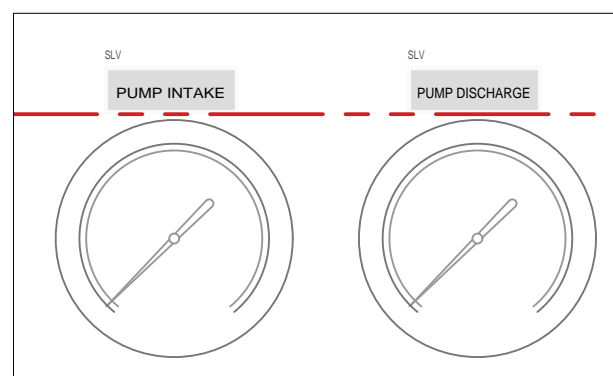
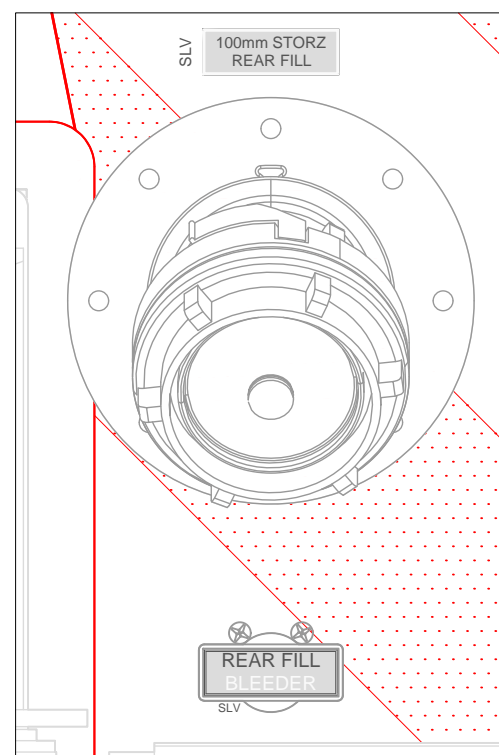
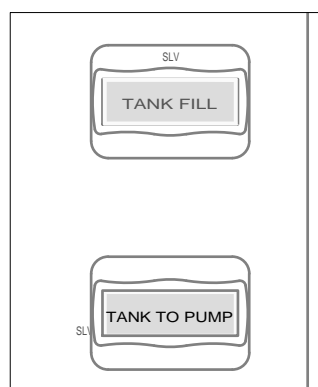
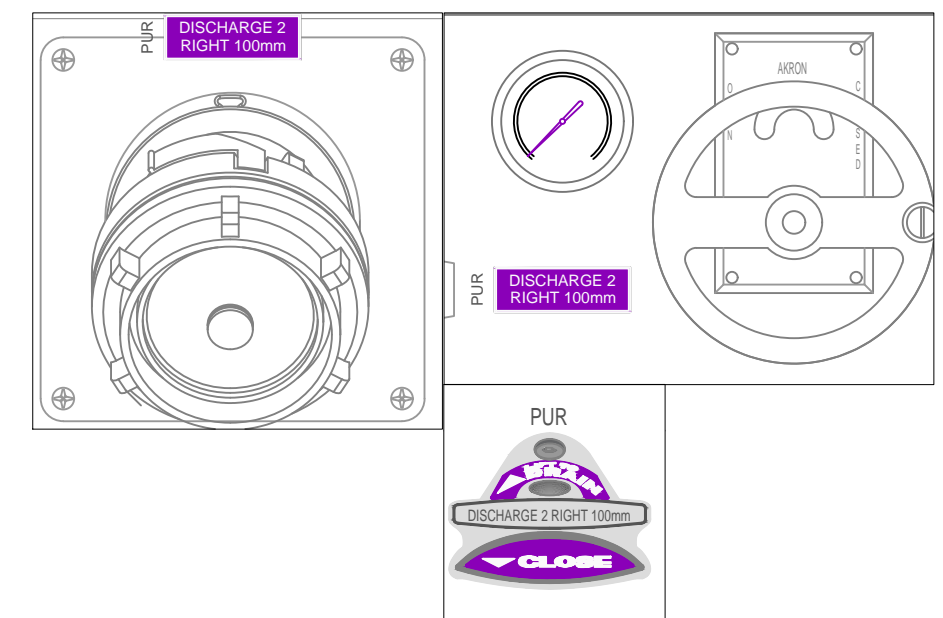
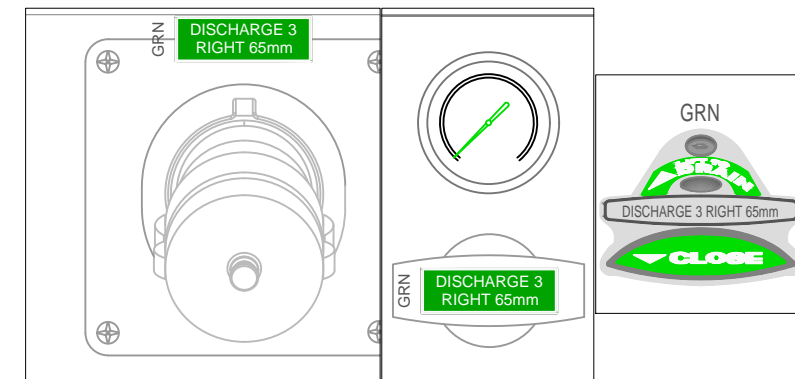
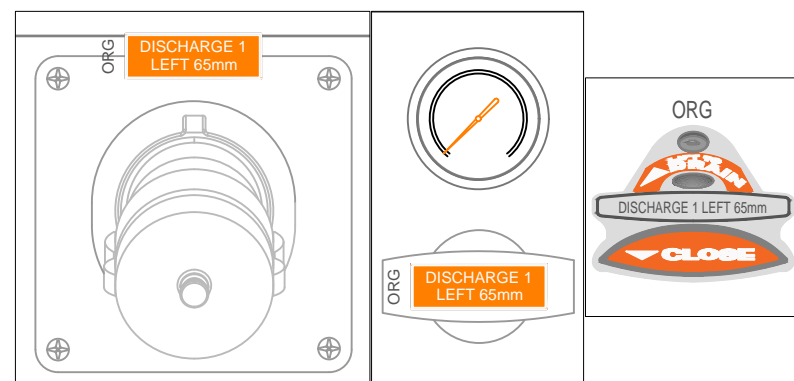
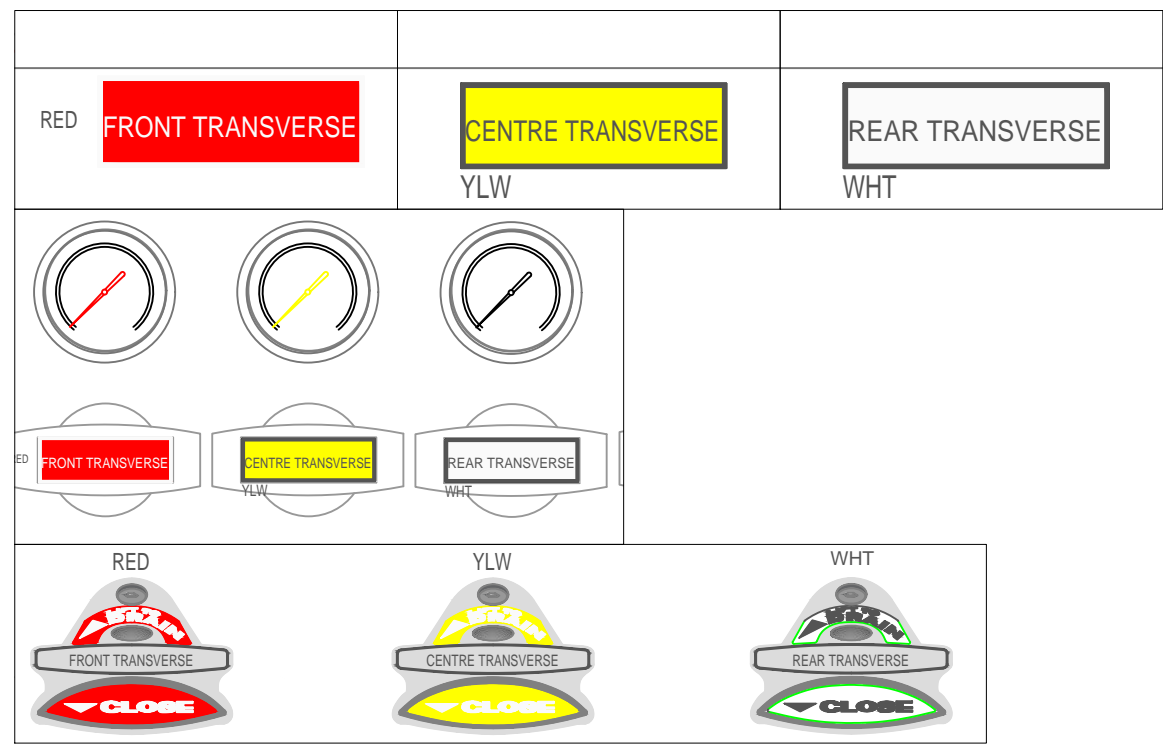

-ALL ALUMINUM CONSTRUCTION - ALL DIMENSIONS ARE IN INCHES & APPROXIMATE

THE CORP. OF THE TOWNSHIP OF UXBRIDGE
JOB No. 22694
DRAWN BY HDS
DATE JUNE 11, 2024
METALFAB LTD.
847 CENTRAL ST. CENTREVILLE NB. CANADA E7K 2E8

TITLE TAGS FOR APPROVAL
METALFAB
FIRE TRUCKS
DRAWING NO. 22694-19 TAGS
REV 0