

NOT SHOWN: (5) 2 1/2" TO 1 1/2" REDUCERS ON LS, RS, & REAR DISCHARGES

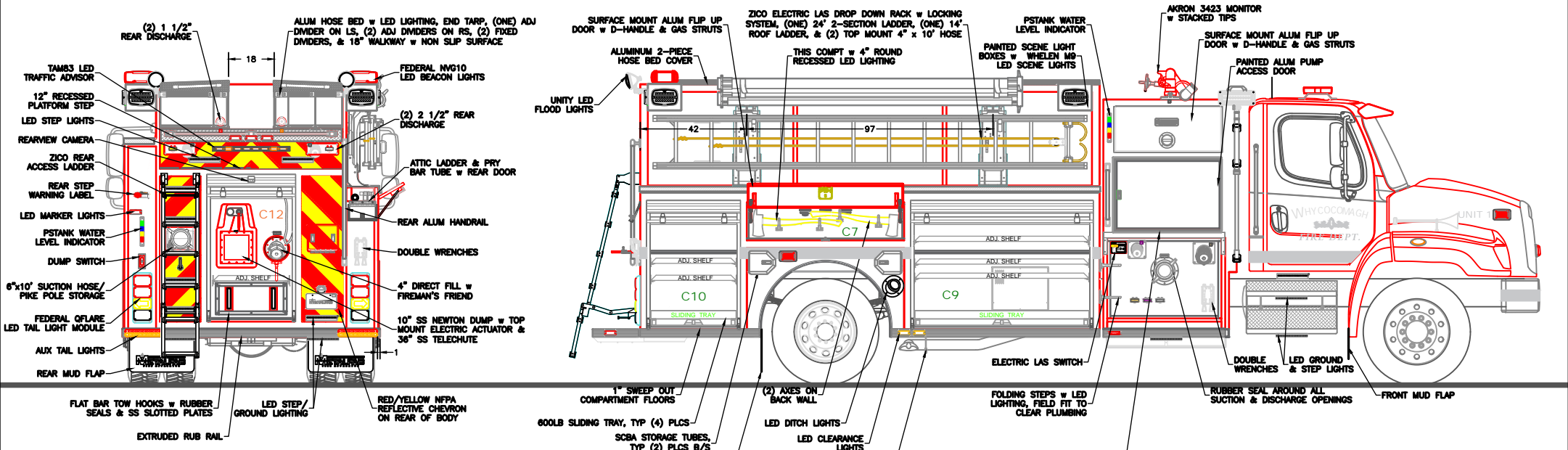
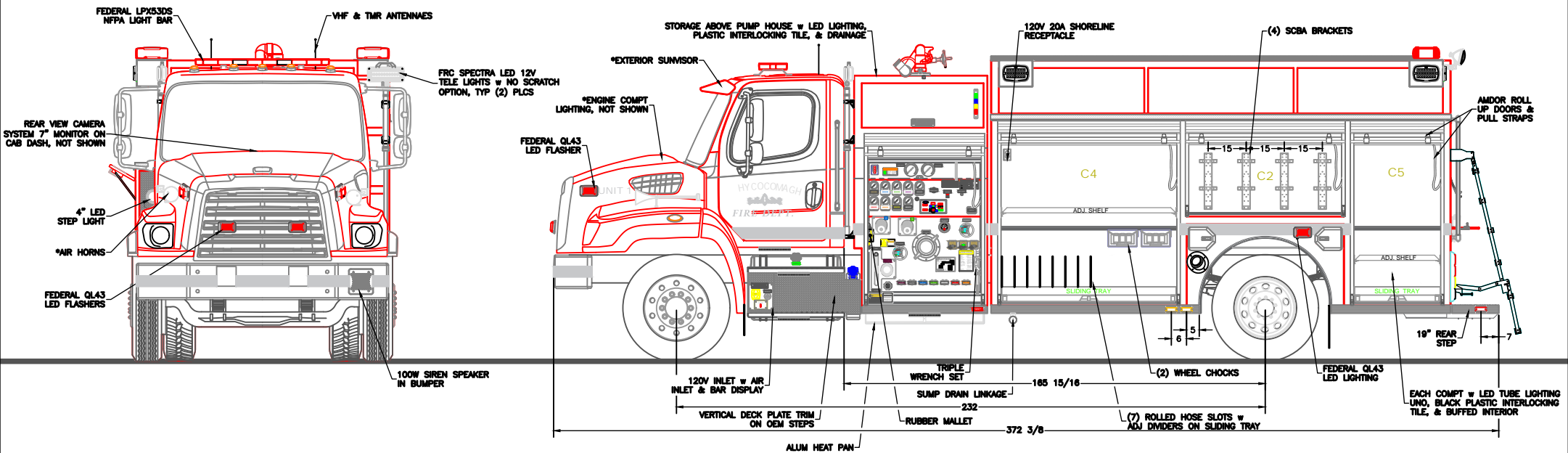

CHASSIS: FREIGHTLINER 114SD 2-DOOR  
 PUMP: HALE RSD-J 1050 IGPM PTO DRIVE  
 TANK: 1400 Imp. Gal. POLYPROPYLENE  
 FOAM: N/A

SUCTION: 1 - 6" RIGHT (MANUAL MIV)  
 1 - 6" LEFT (MANUAL MIV)  
 1 - 4" TANK TO PUMP  
 1 - 2 1/2" LEFT

DISCHARGES: 1 - 4" RIGHT (3" PIPING)  
 1 - 3" MONITOR  
 2 - 2 1/2" LEFT  
 1 - 2 1/2" RIGHT

2 - 2 1/2" REAR  
 1 - 2" TANK FILL  
 2 - 1 1/2" REAR

REV	DESCRIPTION	BY	DATE
0	FIRST ISSUE		

WHYCOCOMAGH, NS FIRE DEPARTMENT	TITLE GENERAL ARRANGEMENT
DWG NO. 22843	
DRAWN BY HDS	
DATE MARCH 20, 2024	
METALFAB LTD. 847 CENTRAL ST. CENTREVILLE NB. CANADA E7K 2E8	DRAWING NO. 22843-19 pg 1 of 3

-ALL ALUMINUM CONSTRUCTION - ALL DIMENSIONS ARE IN INCHES & APPROXIMATE

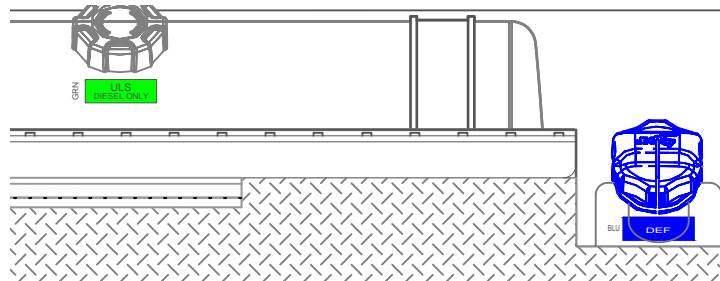
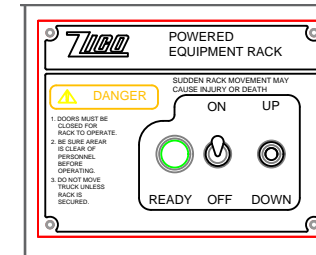
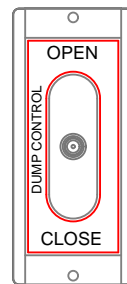
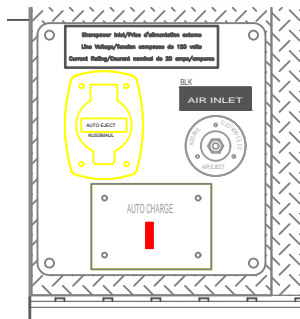
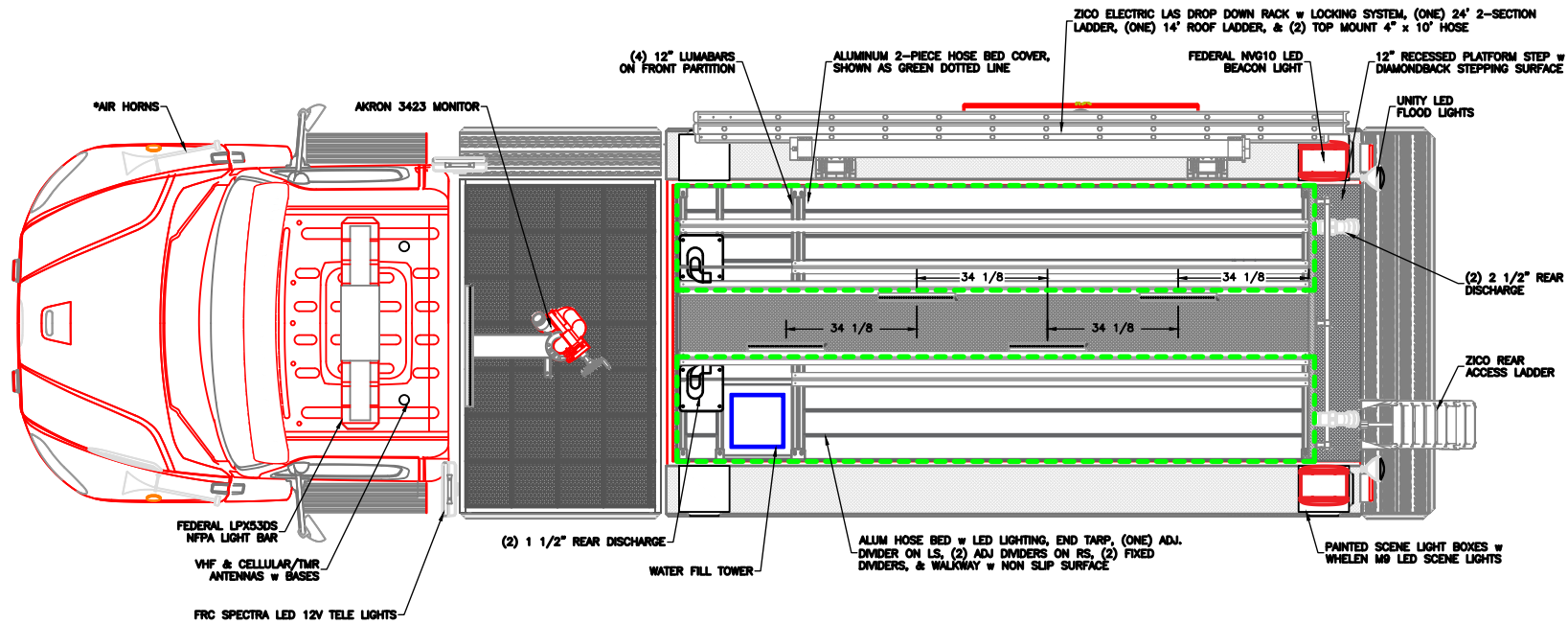

—ALL ALUMINUM CONSTRUCTION — ALL DIMENSIONS ARE IN INCHES & APPROXIMATE

REV	DESCRIPTION	BY	DATE
0	FIRST ISSUE		
1			

WHYCOCOMAGH, NS FIRE DEPARTMENT	TITLE TOP VIEW & TAGS
JOB No. 22843	
DRAWN BY HDS	
DATE MARCH 20, 2024	
METALFAB LTD. 847 CENTRAL ST. CENTREVILLE NB. CANADA E7K 2E8	DRAWING NO. 22843-19 pg 2 of 3
	REV 0

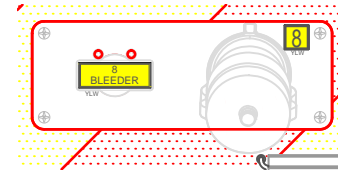
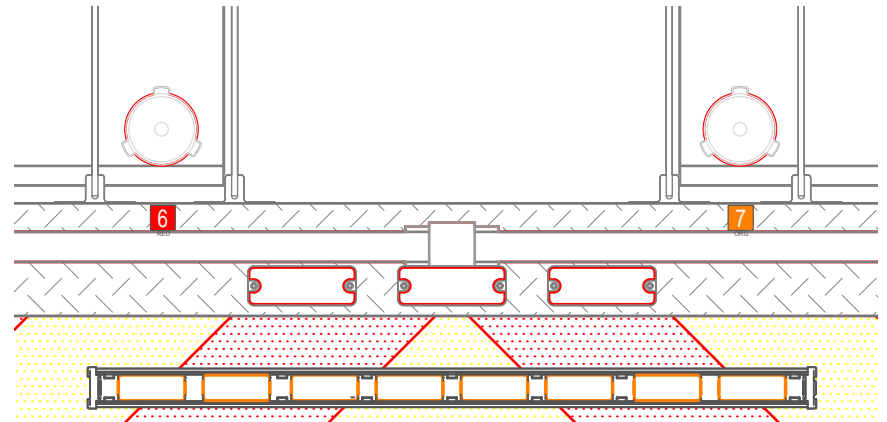
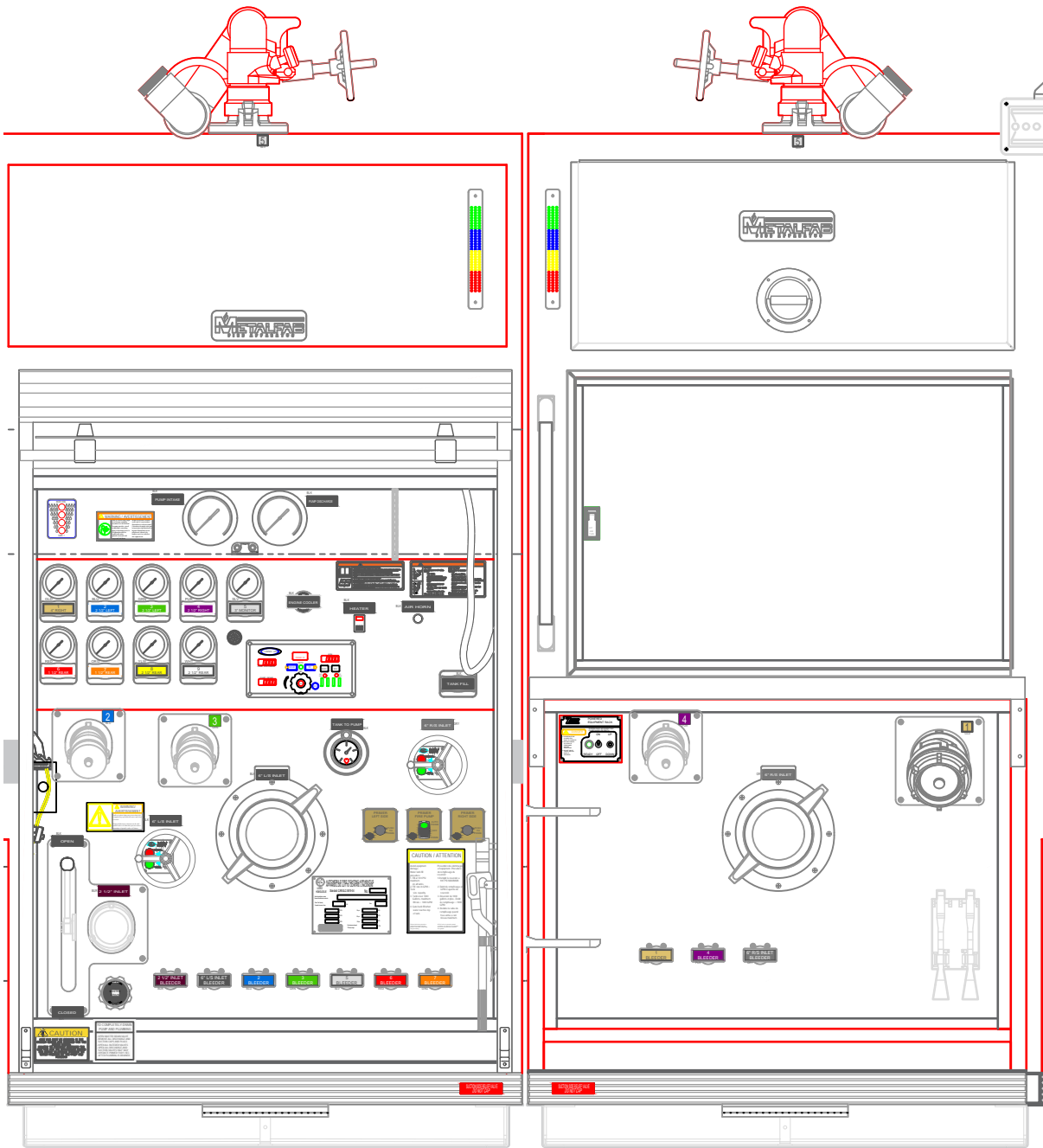

REAR LEFT SIDE

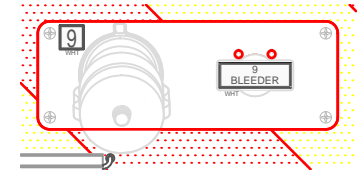

REAR RIGHT SIDE

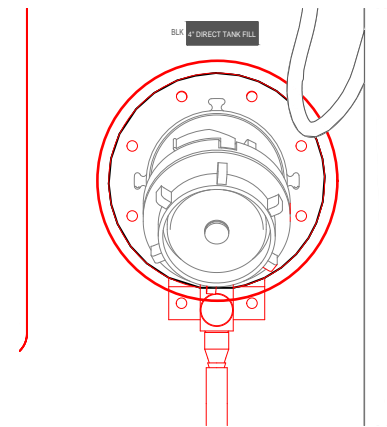

-ALL ALUMINUM CONSTRUCTION - ALL DIMENSIONS ARE IN INCHES & APPROXIMATE

REV	DESCRIPTION	BY	DATE
0	FIRST ISSUE		
1	REVISIONS		

WHYCOCOMAGH, NS  
FIRE DEPARTMENT

JOB No. **22843**

DRAWN BY **HDS**

DATE **MARCH 20, 2024**

METALFAB LTD.  
847 CENTRAL ST. CENTREVILLE  
NB. CANADA E7K 2E8

TITLE OPERATOR'S PANELS

DRAWING NO. 22843-19 pg 3 of 3

REV 0