

CHASSIS: FORD F550 XL 4-DOOR 4X4  
 PUMP: HALE DSD 1050 IGPM MID SHIP  
 TANK: 200 IMP GAL (MAX) POLYPROPYLENE  
 10 IMP GAL FOAM CELL  
 FOAM: FOAMPRO 1600

SUCTION: 1 - 6" LEFT  
 1 - 6" RIGHT  
 1 - 3" TANK TO PUMP (3" PLUMB)  
 1 - 2 1/2" LEFT  
 1 - 2 1/2" RIGHT

DISCHARGES: 2 - 2 1/2" LEFT  
 1 - 2 1/2" RIGHT  
 2 - 2 1/2" REAR  
 1 - 2" TANK FILL  
 1 - 4" RIGHT (3" PLUMBING)  
 2 - 1 1/2" CROSSLAY (FOAM)

REV	DESCRIPTION	BY	DATE
2	REMOVE FOAM FILL FROM THE RS PANEL	HDS	JUNE 27, 2025
1	UPDATE STAINLESS PANELS; UPDATE ADDITIONAL HANDRAILS, AS SHOWN	HDS	JUN 11, 2025
0	FIRST ISSUE		

REVISIONS	
NO.	DESCRIPTION
1	ADJ. DIVIDERS, LED LIGHTING, & COVER TARP
2	12' FRESNO LADDER & PIKE POLE ON TOP OF BODY IN TRAY
3	(4) SCBA BRACKETS ON UNISTRUTS
4	FOLDING STEPS w LED LIGHTING, FIELD FIT TO CLEAR PLUMBING

COLES ISLAND FIRE DEPARTMENT		TITLE ACCESSORIES MOUNTING	
JOB No.	23264		
DRAWN BY	HDS		
DATE	APRIL 23, 2025		
METALFAB LTD. 847 CENTRAL ST. CENTREVILLE NB. CANADA E7K 2E8			
DRAWING NO. 23264-19		REV	2

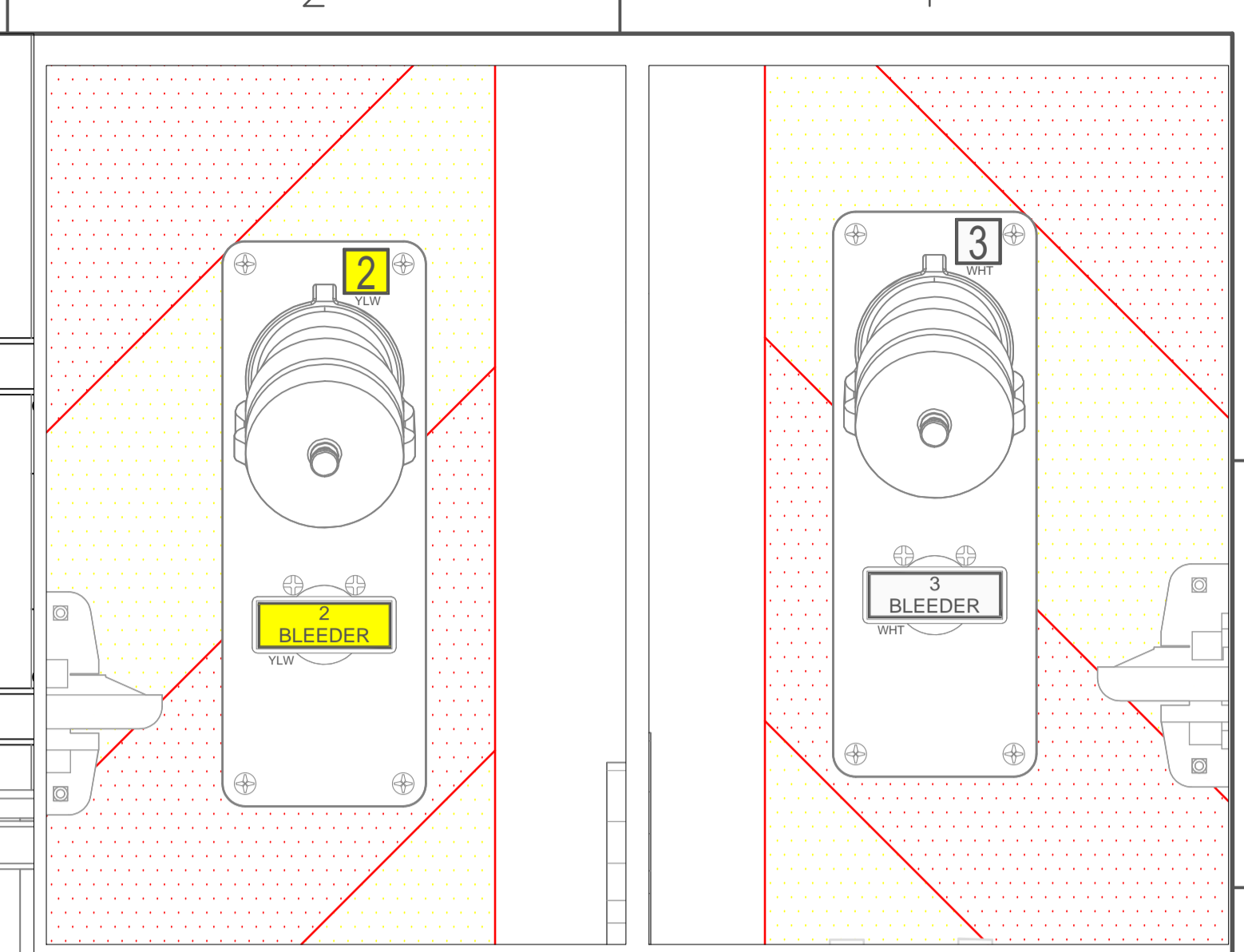
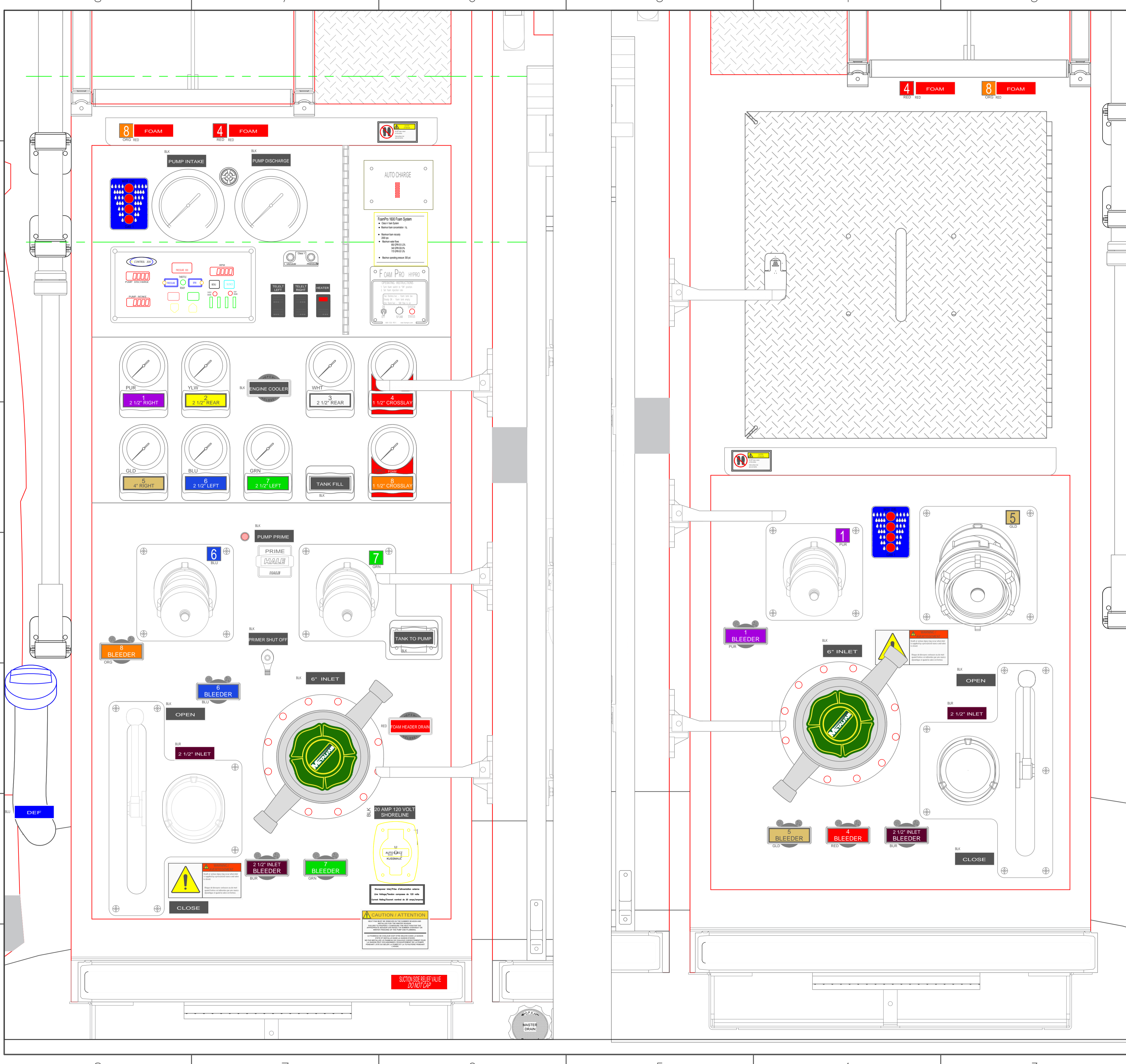

REAR LS

REAR RS

REV	DESCRIPTION	BY	DATE
2	REMOVE FOAM FILL FROM THE RS PANEL	HDS	JUNE 27, 2025
1	UPDATE STAINLESS PANELS; UPDATE ADDITIONAL HANDRAILS, AS SHOWN	HDS	JUN 11, 2025
0	FIRST ISSUE		

<b>COLES ISLAND FIRE DEPARTMENT</b>		<b>TITLE PUMP PANEL LAYOUT</b>	
JOB No. 23264 DRAWN BY HDS DATE APRIL 23 2025			
METALFAB LTD. 847 CENTRAL ST. CENTREVILLE NB. CANADA E7K 2E8		DRAWING NO. 23264-19	REV 2

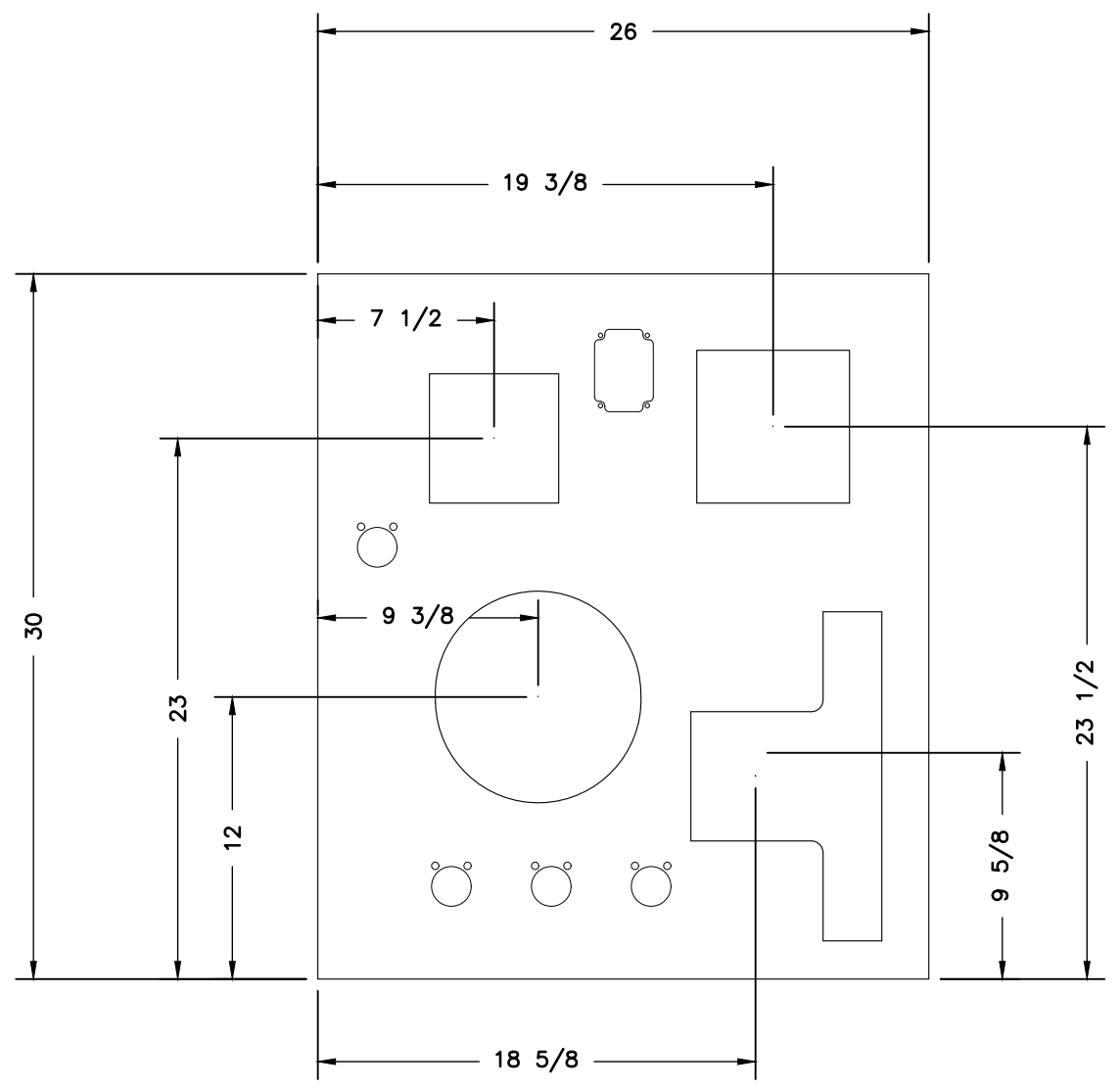
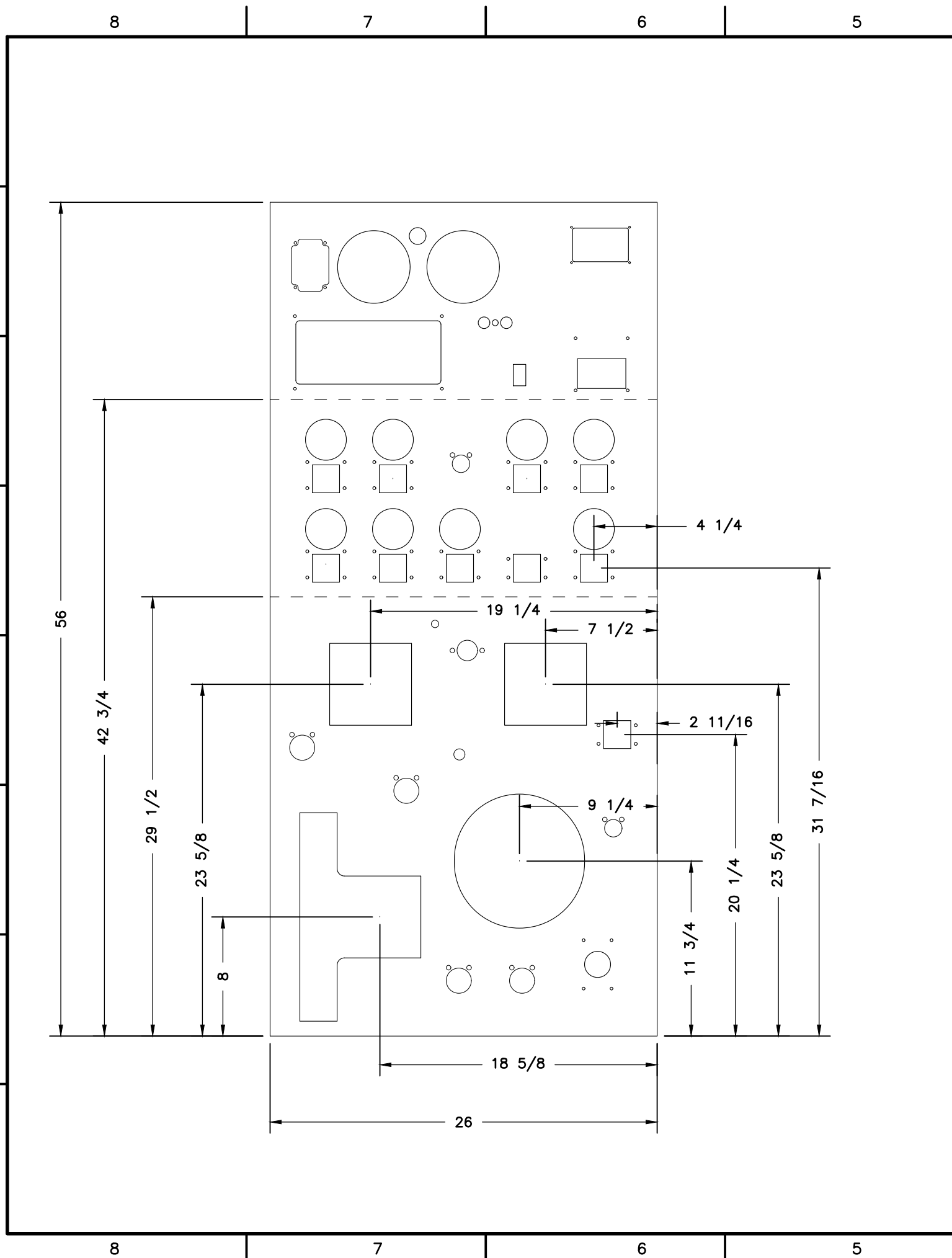

ALL PANELS ARE 14 Ga. STAINLESS STEEL  
 3/8" ADDED TO WIDTH IN DXF  
 REMOVE ALL SHARP EDGES/BURRS  
 POLISH IN SANDER AFTER FITTED  
 DXF - O:\CAD\COLES ISLAND\SSPNLS.DXF

COLES ISLAND FIRE DEPARTMENT		TITLE SS PUMP PANELS	
JOB No.	23264	 METALFAB LTD. 847 CENTRAL ST. CENTREVILLE NB. CANADA E7K 2E8	
DRAWN BY	T CULLINS		
DATE	JUNE 11 2025		
MANUFACTURING TOLERANCES		DRAWING NO.	23264-19
UNLESS OTHERWISE NOTED: ALL MACHINE OPERATIONS HAVE A TOLERANCE OF (+/-) 1/16"		REV	0

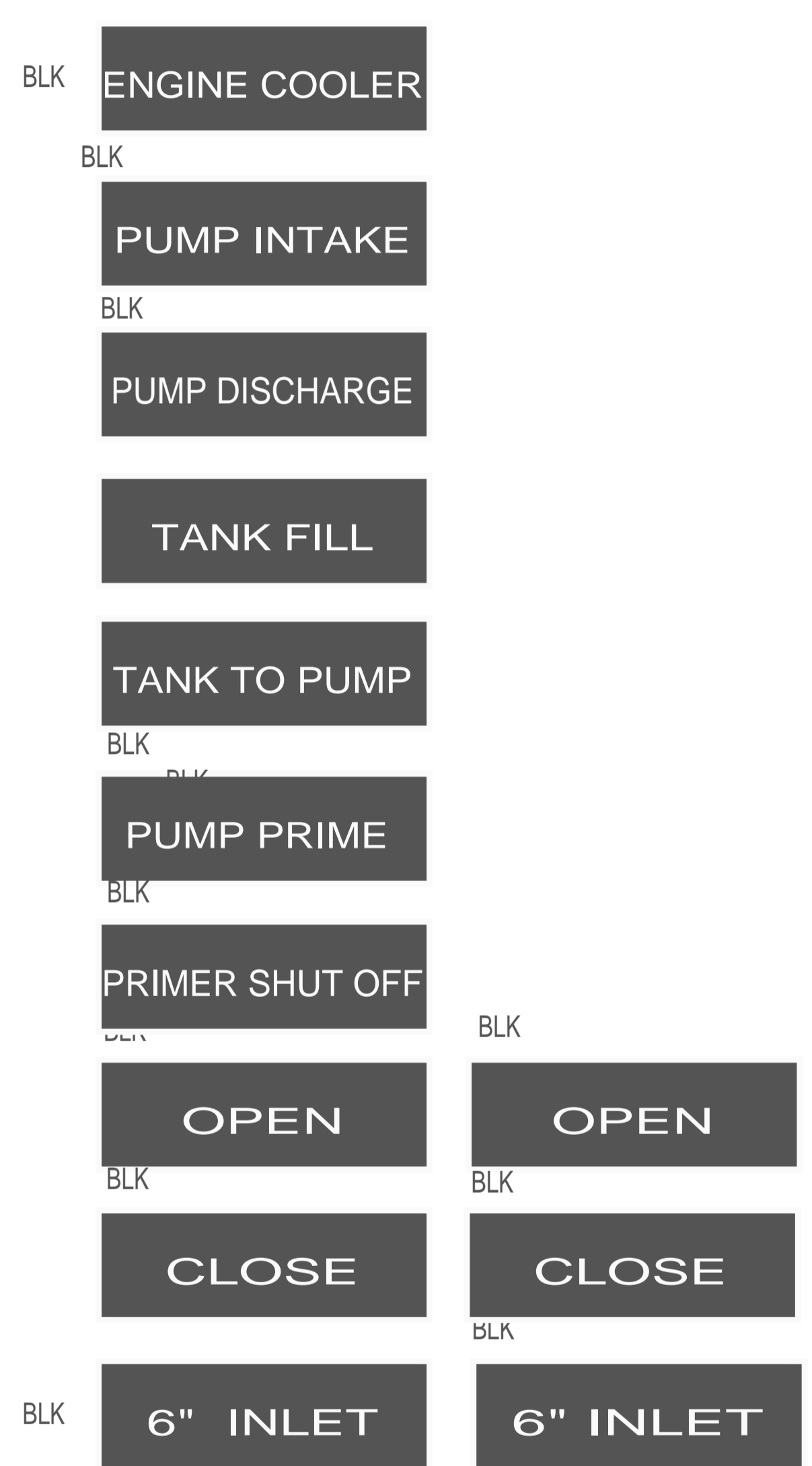
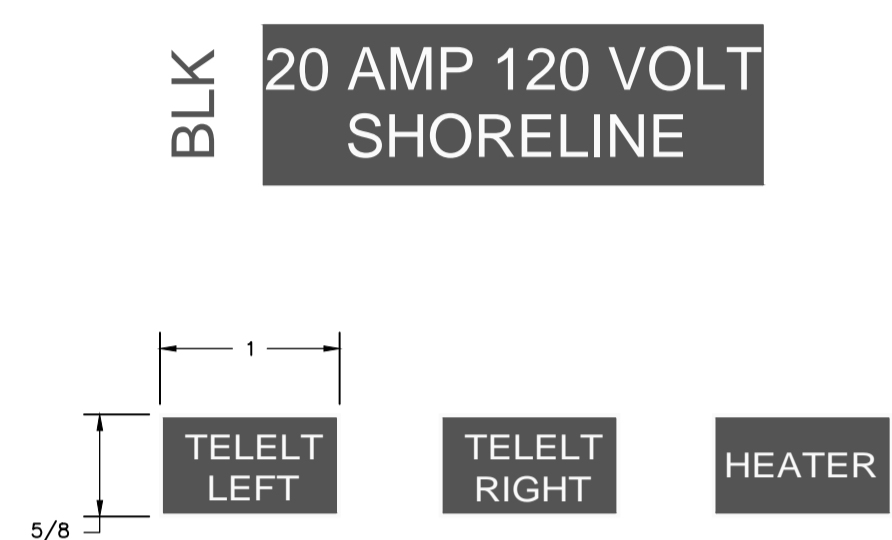
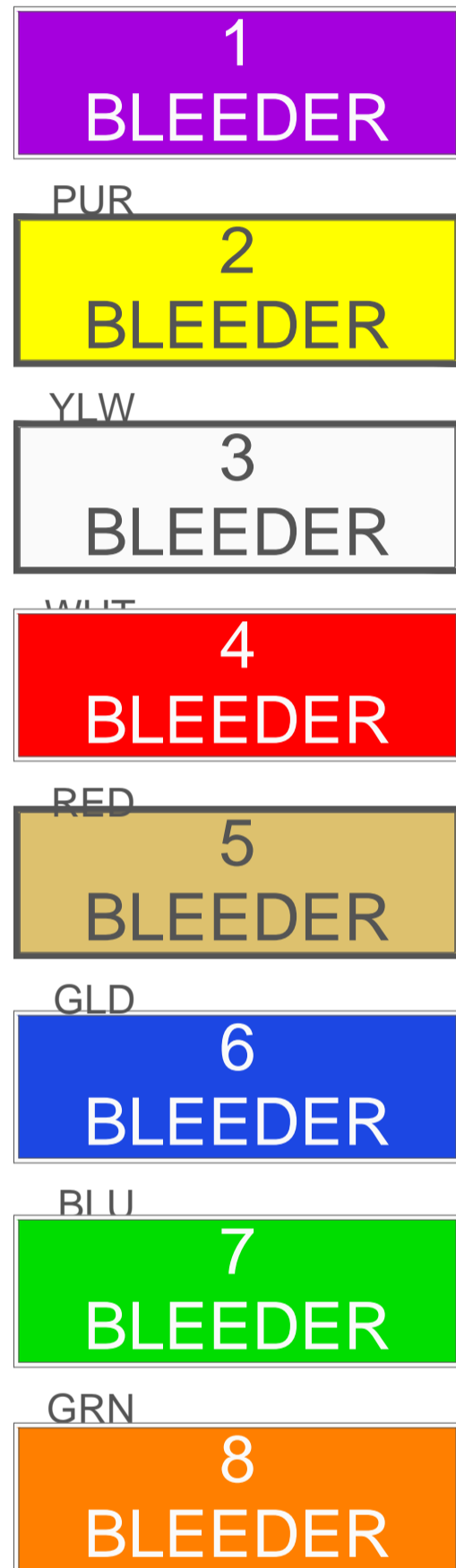
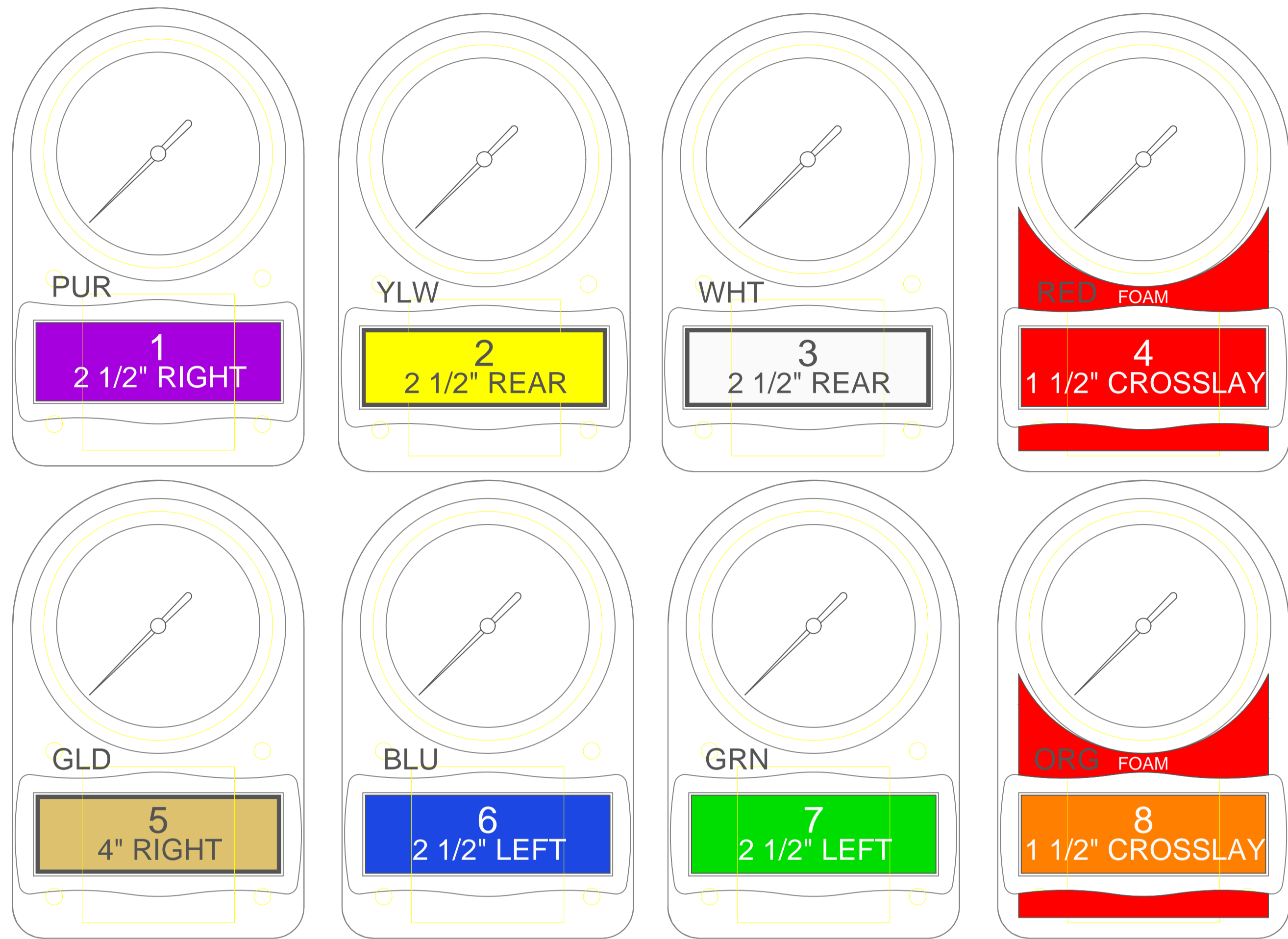

RED SUCTION SIDE RELIEF VALVE  
DO NOT CAP

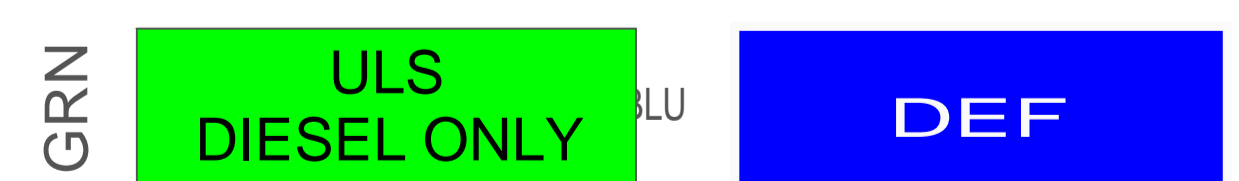
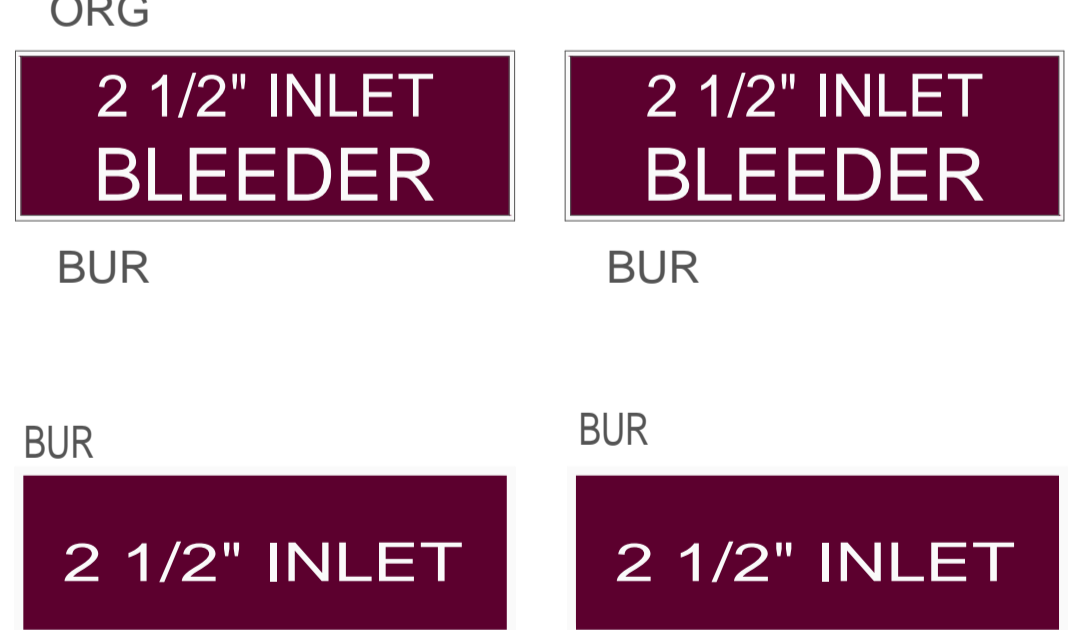
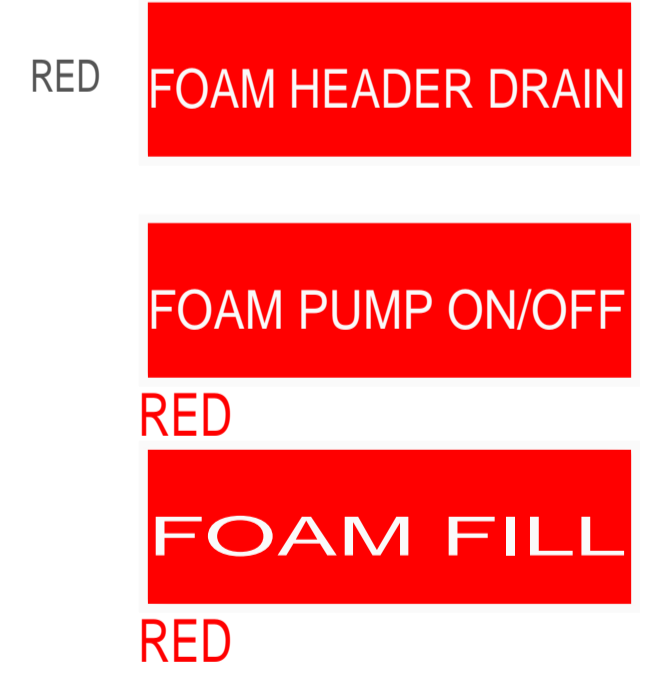
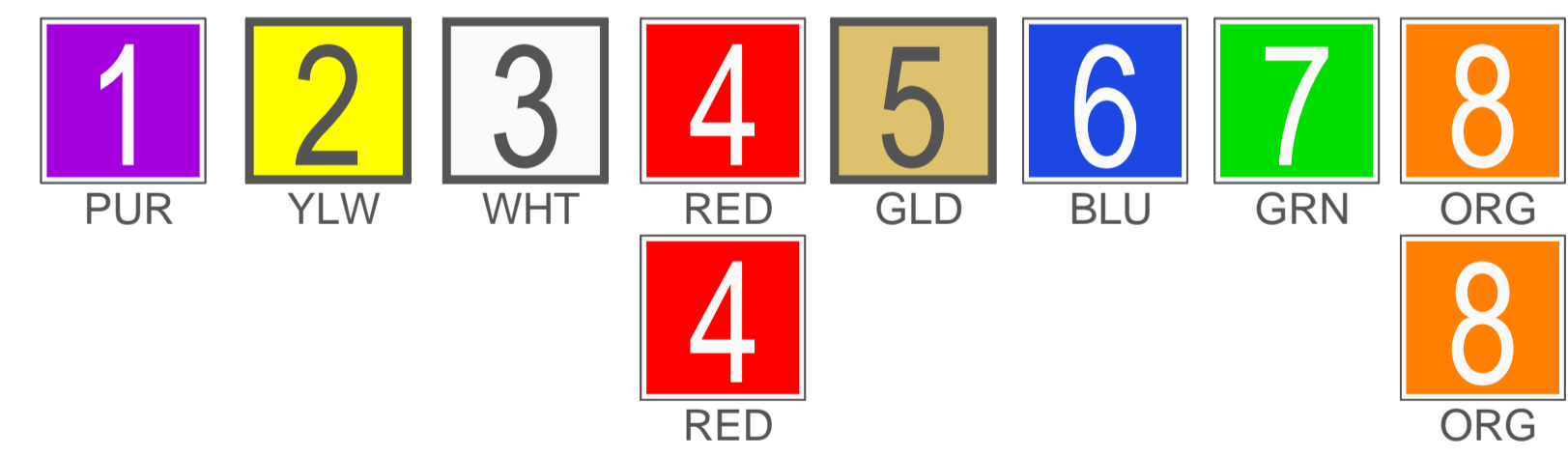

1	UPDATE STAINLESS PANELS; UPDATE ADDITIONAL HANDRAILS, AS SHOWN	HDS	JUN 11, 2025
0	FIRST ISSUE	----	----
REV	DESCRIPTION	BY	DATE
REVISIONS			
COLES ISLAND FIRE DEPARTMENT		TITLE PUMP PANEL LAYOUT	
JOB No.	23264		
DRAWN BY	HDS		
DATE	APRIL 23 2025		
METALFAB LTD. 847 CENTRAL ST. CENTREVILLE NB. CANADA E7K 2E8		DRAWING NO.	23264-19
		REV	1