

CHASSIS: FORD F550 4 DOOR 4X4  
 PUMP: HALE DSD 1050 IGPM MID SHIP  
 TANK: 165 IG (MIN) - 200 IG (MAX) POLYPROPYLENE  
 10 IMP GAL FOAM CELL  
 FOAM: FOAMPRO 1600

SUCTION: 1 - 6" LEFT (ELECTRIC GATE)  
 1 - 6" RIGHT (NO GATE)  
 1 - 3" TANK TO PUMP  
 1 - 2 1/2" LEFT  
 1 - 2 1/2" RIGHT

DISCHARGES: 1 - 4" RIGHT (3" PLUMBING)  
 2 - 2 1/2" LEFT  
 1 - 2 1/2" RIGHT  
 1 - 2 1/2" REAR (FOAM)  
 1 - 2" TANK FILL  
 2 - 1 1/2" CROSSLAY (FOAM)

REV	DESCRIPTION	BY	DATE
0	FIRST ISSUE		

  

REVISIONS	

<b>DUMFRIES NEW BRUNSWICK          FIRE DEPARTMENT</b> JOB No. 21981 DRAWN BY HDS DATE JULY 4, 2024 METALFAB LTD. 847 CENTRAL ST. CENTREVILLE NB. CANADA E7K 2E8	<b>TITLE GENERAL ARRANGEMENT</b>  DRAWING NO. 21981-19 PG 1 OF 2 REV 0
--	---

\*-COMES WITH CHASSIS -ALL ALUMINUM CONSTRUCTION - ALL DIMENSIONS ARE IN INCHES & APPROXIMATE

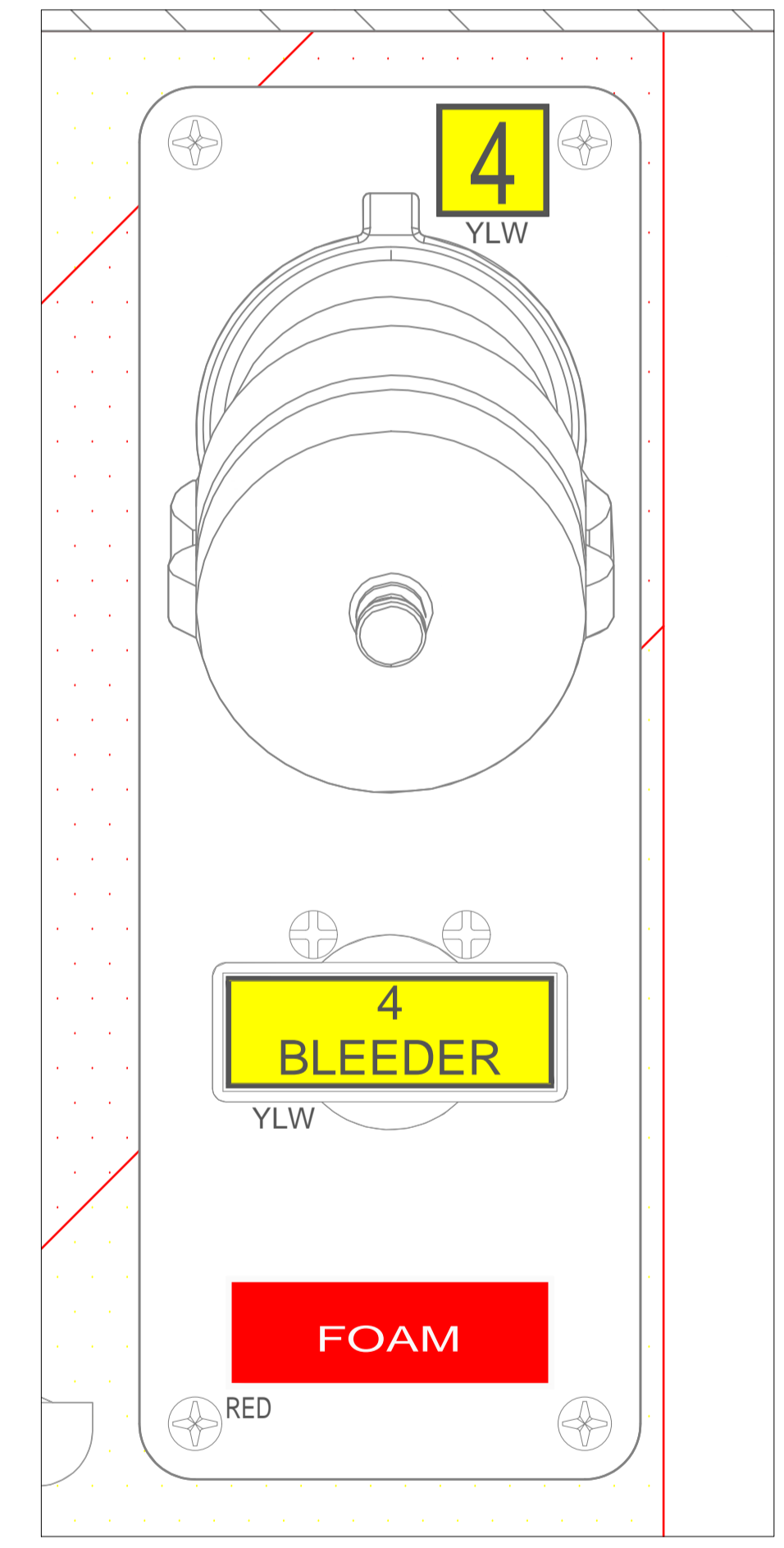
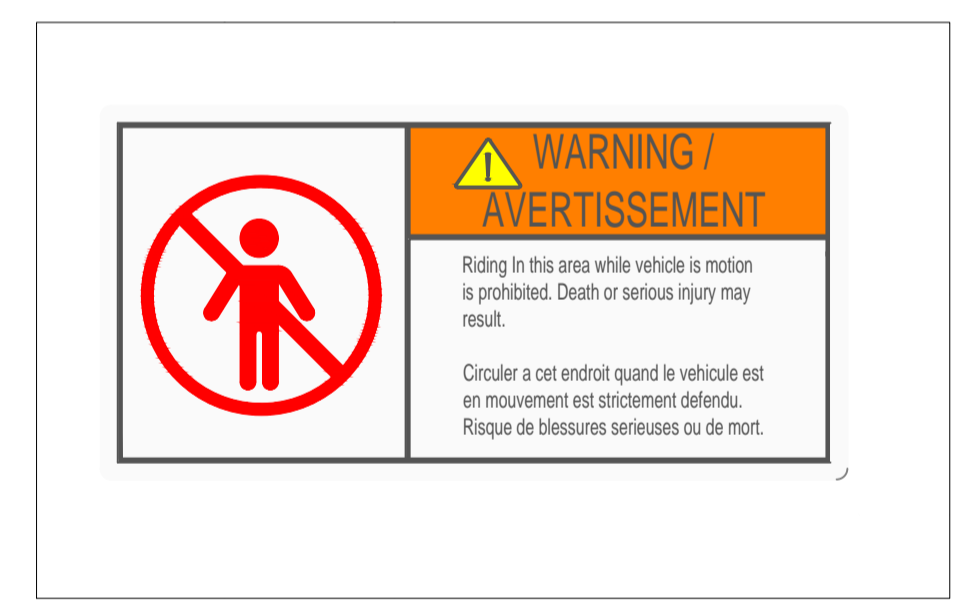
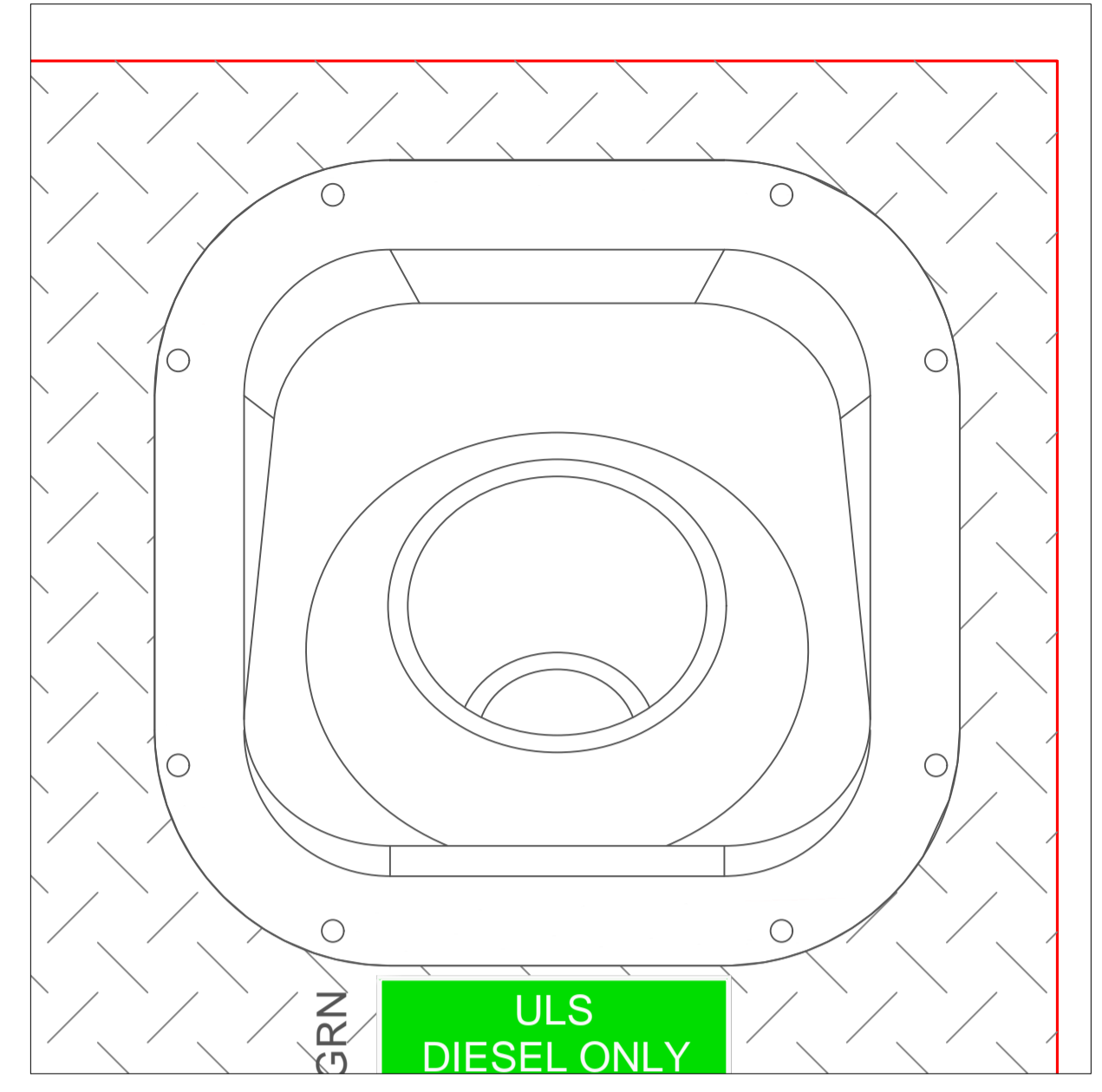
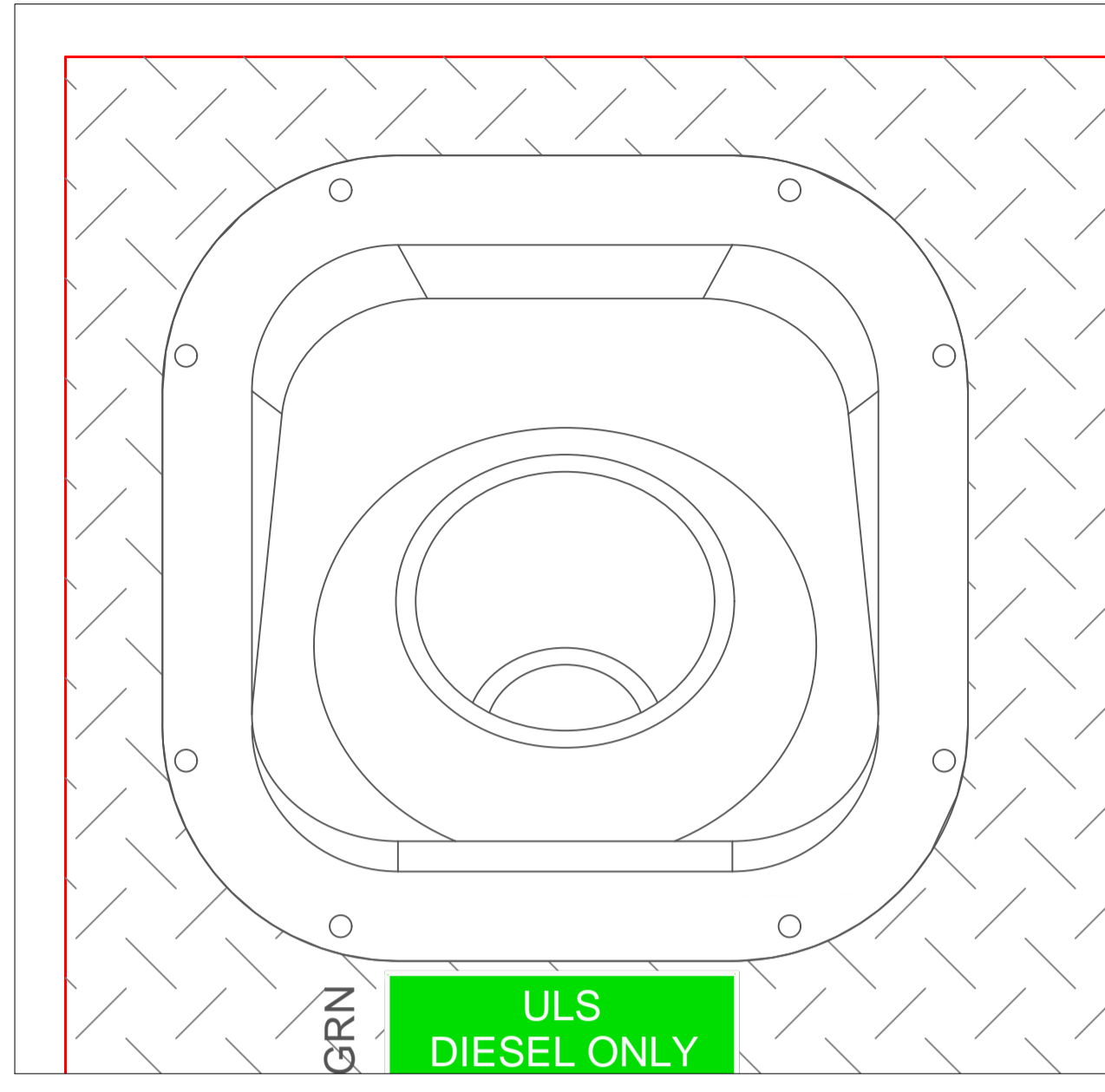
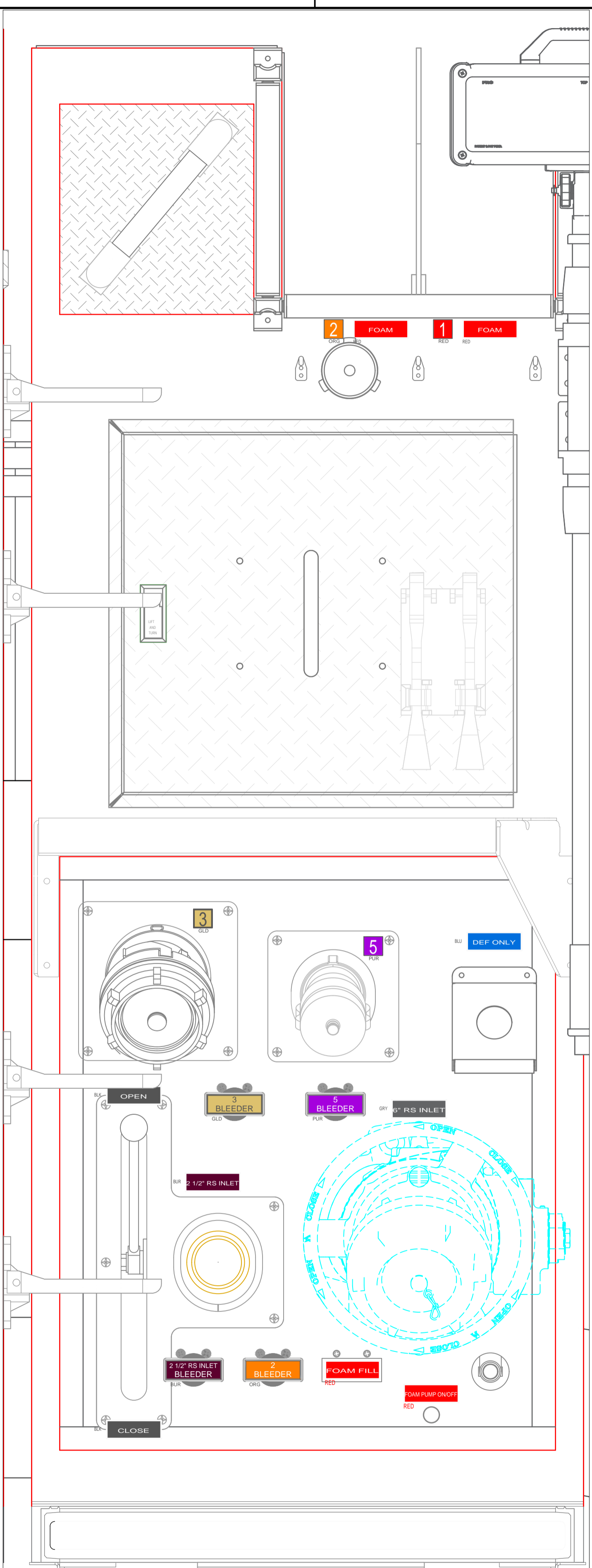
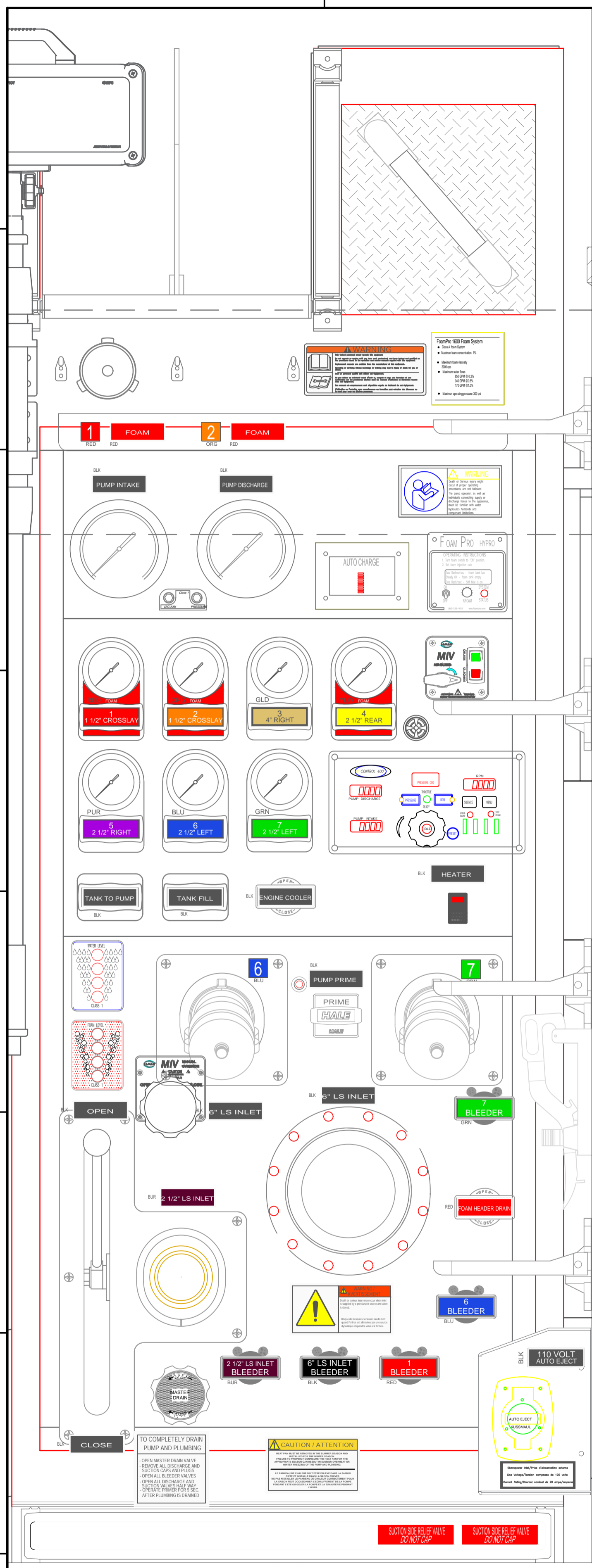

REV	FIRST ISSUE	DESCRIPTION	BY	DATE
0				

REVISIONS	

DUMFRIES NEW BRUNSWICK FIRE DEPARTMENT		TITLE OPERATOR'S PANELS & TAGS	
JOB No.	21981		
DRAWN BY	HDS		
DATE	JULY 4, 2024		
METALFAB LTD. 847 CENTRAL ST. CENTREVILLE NB. CANADA E7K 2E8		DRAWING NO.	21981-19 PG 2 OF 2
		REV	0

\*-COMES WITH CHASSIS -ALL ALUMINUM CONSTRUCTION - ALL DIMENSIONS ARE IN INCHES & APPROXIMATE