

CHASSIS: SPARTAN METRO STAR MFD 10" RAISED ROOF
 PUMP: HALE DSD 1250 IGPM SPLIT SHAFT
 TANK: 2200 Imp. Gal. POLYPROPYLENE
 FOAM: N/A

SUCTION: 1 - 6" LEFT (ELECTRIC GATE)
 1 - 6" RIGHT (ELECTRIC GATE)
 1 - 4" TANK TO PUMP (4" PLUMB)
 1 - 4" RIGHT (4" PLUMBING)
 1 - 2 1/2" LEFT (ELECTRIC)

DISCHARGES: 1 - 4" RIGHT (4" VALVE)
 1 - 4" FRONT (4" PLUMBING)
 1 - 2 1/2" LEFT
 1 - 2 1/2" RIGHT
 1 - 2 1/2" REAR

REV	DESCRIPTION	BY	DATE
0	FIRST ISSUE		
REVISIONS			
ELMSDALE FIRE DEPARTMENT		TITLE GENERAL ARRANGEMENT	
JOB No.	23128		
DRAWN BY	HDS		
DATE	JULY 21, 2025		
METALFAB LTD. 847 CENTRAL ST. CENTREVILLE NB. CANADA E7K 2E8		DRAWING NO. 23128-19 SHT 1 OF 3	REV 0

- ALL ALUMINUM CONSTRUCTION - ALL DIMENSIONS ARE IN INCHES & APPROXIMATE - *INCLUDED w CHASSIS -

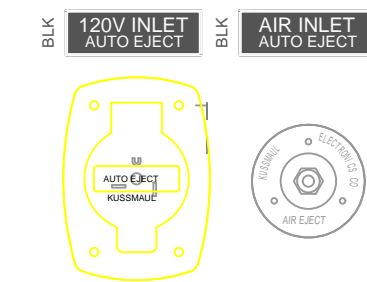
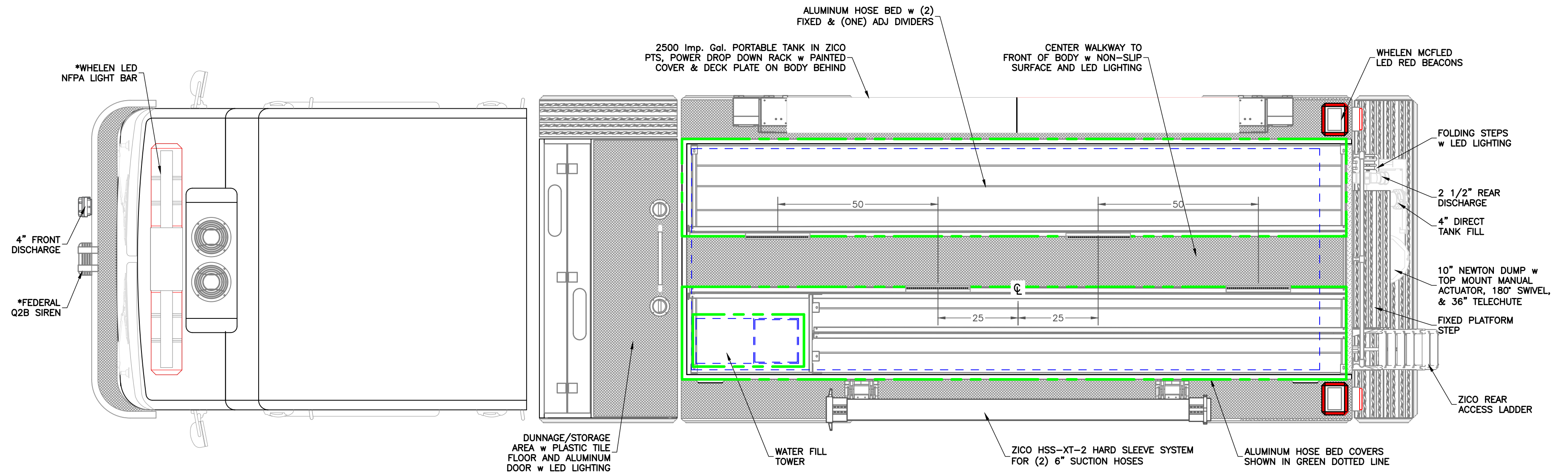

Shorepower Inlet/Prise d'alimentation externe
Line Voltage/Tension comprise de 120 volts
Current Rating/Courant nominal de 30 amps/ampères

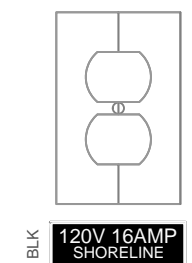
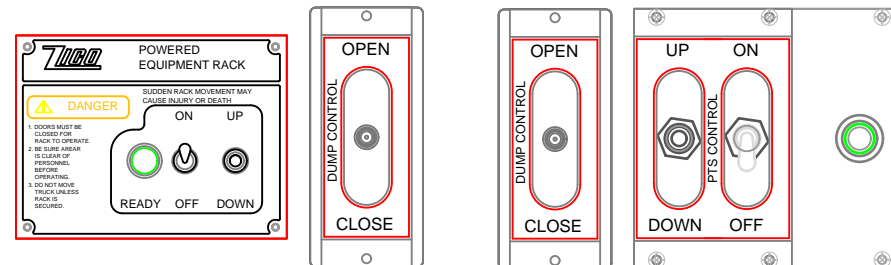
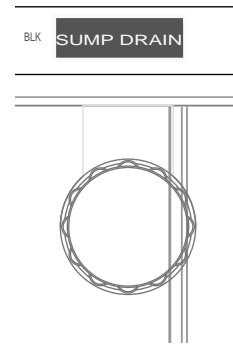
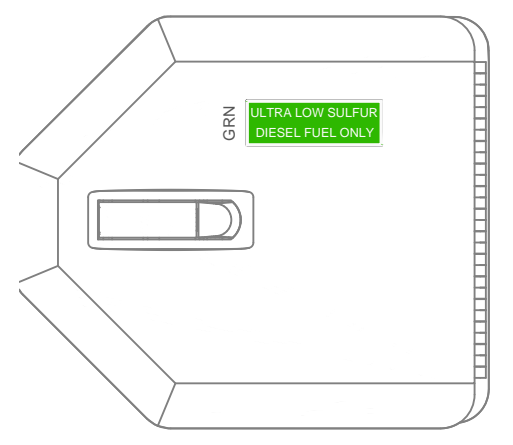

C5 & C10

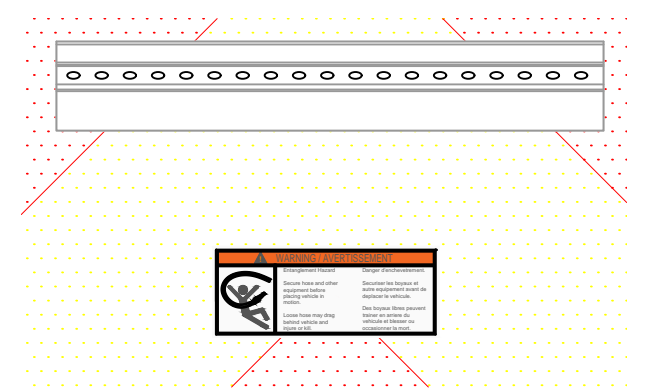

- ALL ALUMINUM CONSTRUCTION - ALL DIMENSIONS ARE IN INCHES & APPROXIMATE - *INCLUDED w CHASSIS -

REV	DESCRIPTION	BY	DATE
0	FIRST ISSUE		

REVISIONS	
NO.	DESCRIPTION

ELMSDALE FIRE DEPARTMENT		TITLE TOP VIEW	
JOB No.	23128		
DRAWN BY	HDS		
DATE	JULY 21, 2025		
METALFAB LTD. 847 CENTRAL ST. CENTREVILLE NB. CANADA E7K 2E8		DRAWING NO.	23128-19 SHT 2 OF 3
		REV	0

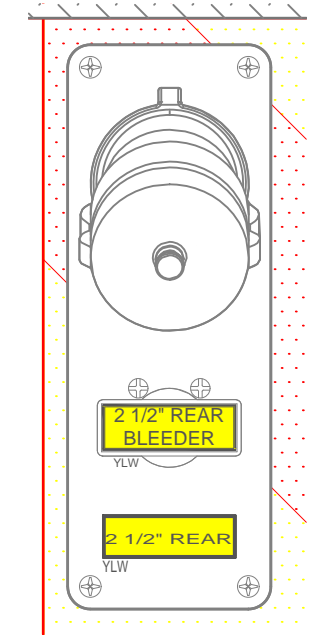
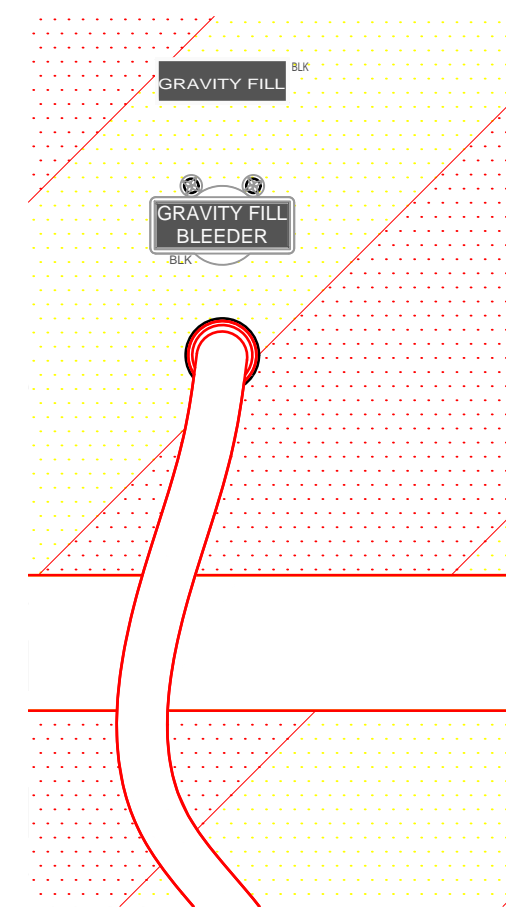
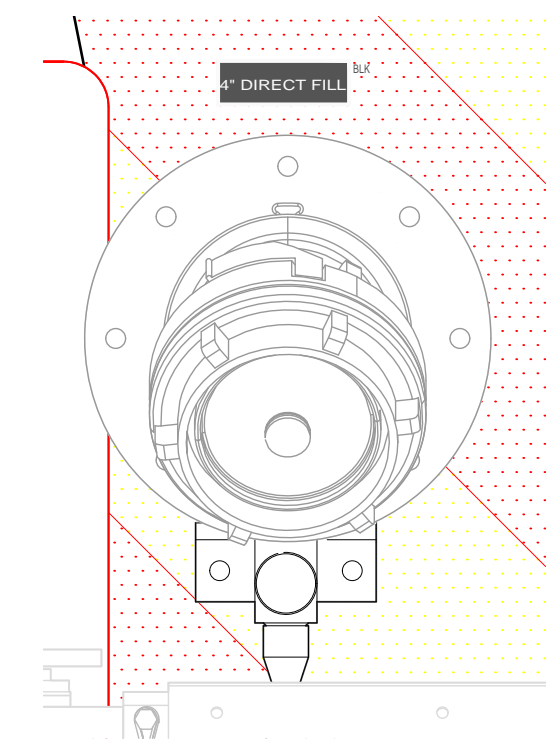
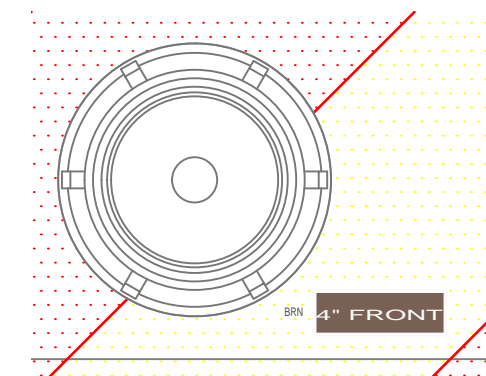
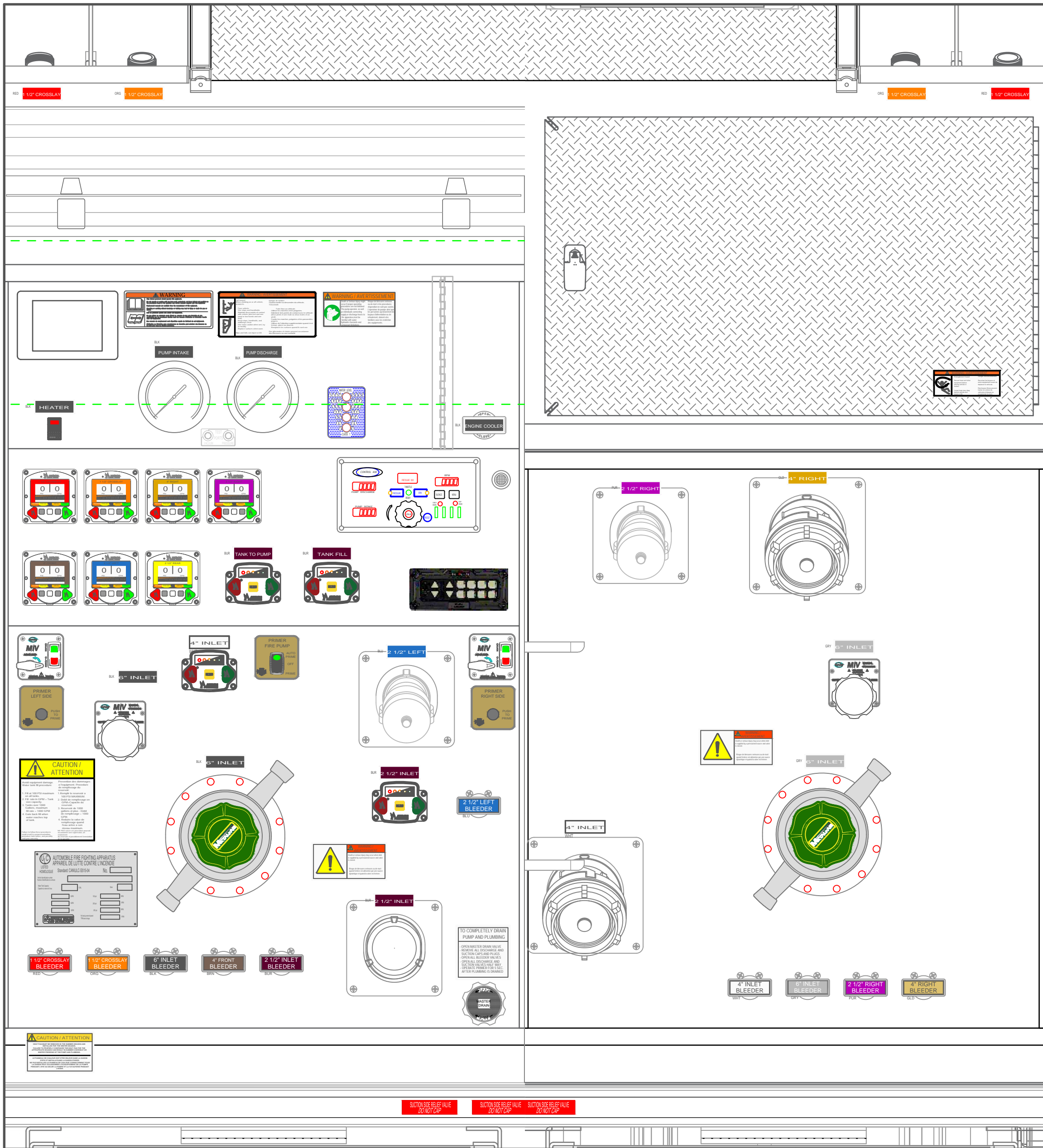

- ALL ALUMINUM CONSTRUCTION - ALL DIMENSIONS ARE IN INCHES & APPROXIMATE - *INCLUDED w CHASSIS -

REV	DESCRIPTION	BY	DATE
0	FIRST ISSUE		

REVISIONS	
NO.	DESCRIPTION

ELMSDALE FIRE DEPARTMENT		TITLE OPERATOR'S PANELS	
JOB No.	23128		
DRAWN BY	HDS		
DATE	JULY 21, 2025		
METALFAB LTD. 847 CENTRAL ST. CENTREVILLE NB. CANADA E7K 2E8			
DRAWING NO.		23128-19 SHT 3 OF 3	REV 0