

CHASSIS: FORD F550 4 DOOR 4X4	SUCTION: 1 - 6" LEFT (ELECTRIC GATE) 1 - 6" RIGHT (ELECTRIC GATE) 1 - 3" TANK TO PUMP 1 - 2 1/2" LEFT 1 - 2 1/2" RIGHT	DISCHARGES: 2 - 2 1/2" LEFT 1 - 2 1/2" RIGHT 2 - 2 1/2" REAR (LS FOAM) 1 - 2" TANK FILL 1 - 4" RIGHT (3" PLUMBING) 2 - 1 1/2" CROSSLAY (FOAM)
PUMP: HALE DSD 1050 IGPM MID SHIP		
TANK: 200 IMP GAL (MAX) POLYPROPYLENE 10 IMP GAL FOAM CELL		
FOAM: FOAMPRO 1600		

REV	DESCRIPTION	BY	DATE
0	FIRST ISSUE		

LONG REACH FIRE DEPARTMENT		GENERAL ARRANGEMENT	
JOB No.	22725		
DRAWN BY	HDS		
DATE	JANUARY 28, 2025		
METALFAB LTD. 847 CENTRAL ST. CENTREVILLE NB. CANADA E7K 2E8		DRAWING NO. 22725-19 PG 1 OF 2	REV 0

*-COMES WITH CHASSIS -ALL ALUMINUM CONSTRUCTION - ALL DIMENSIONS ARE IN INCHES & APPROXIMATE

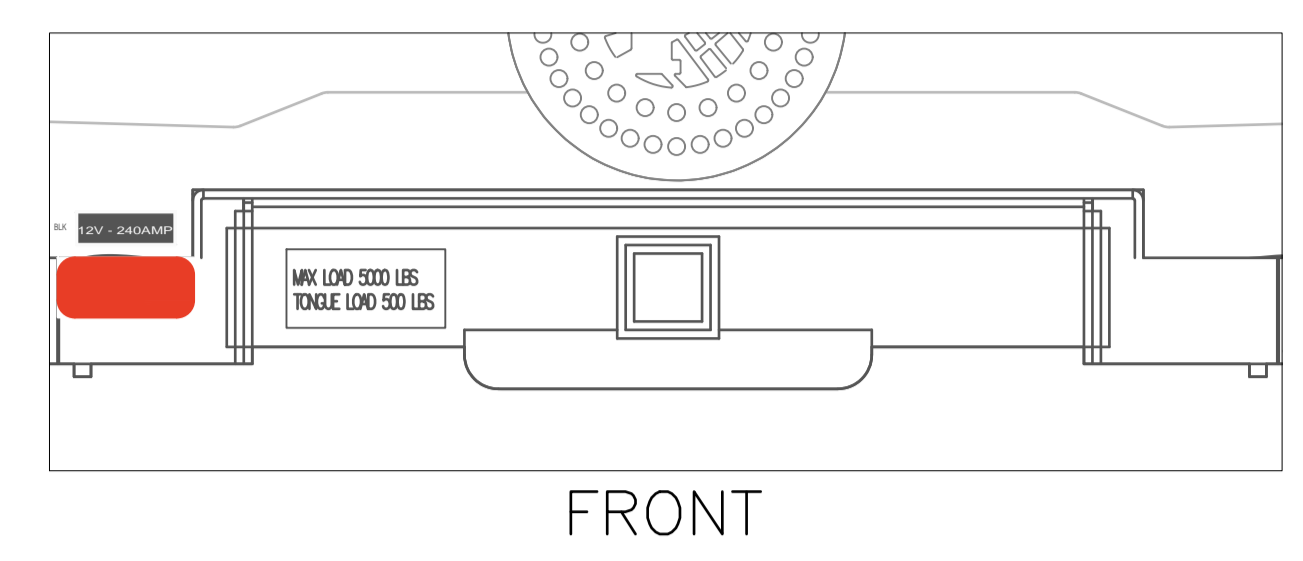
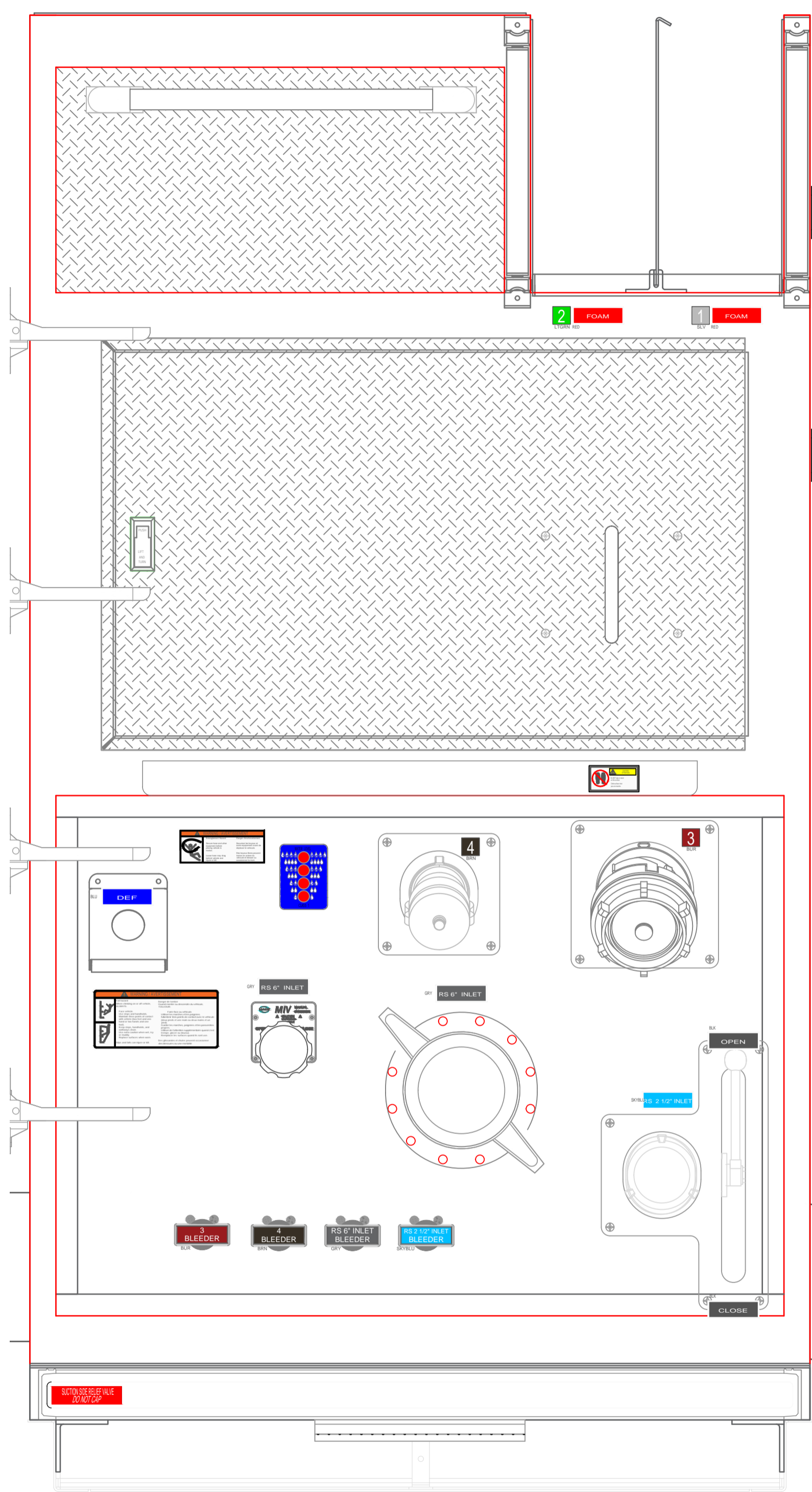
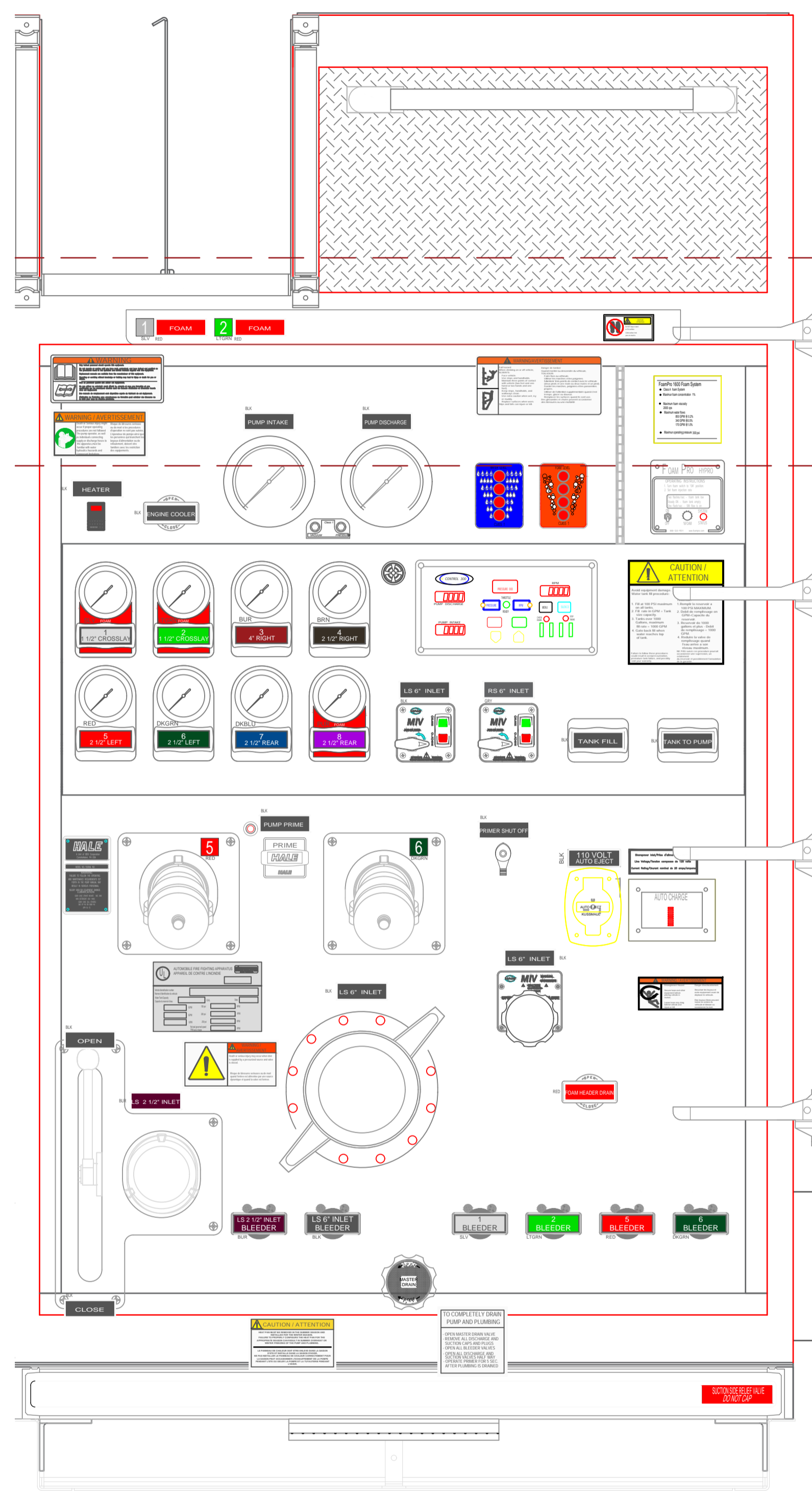

FRONT

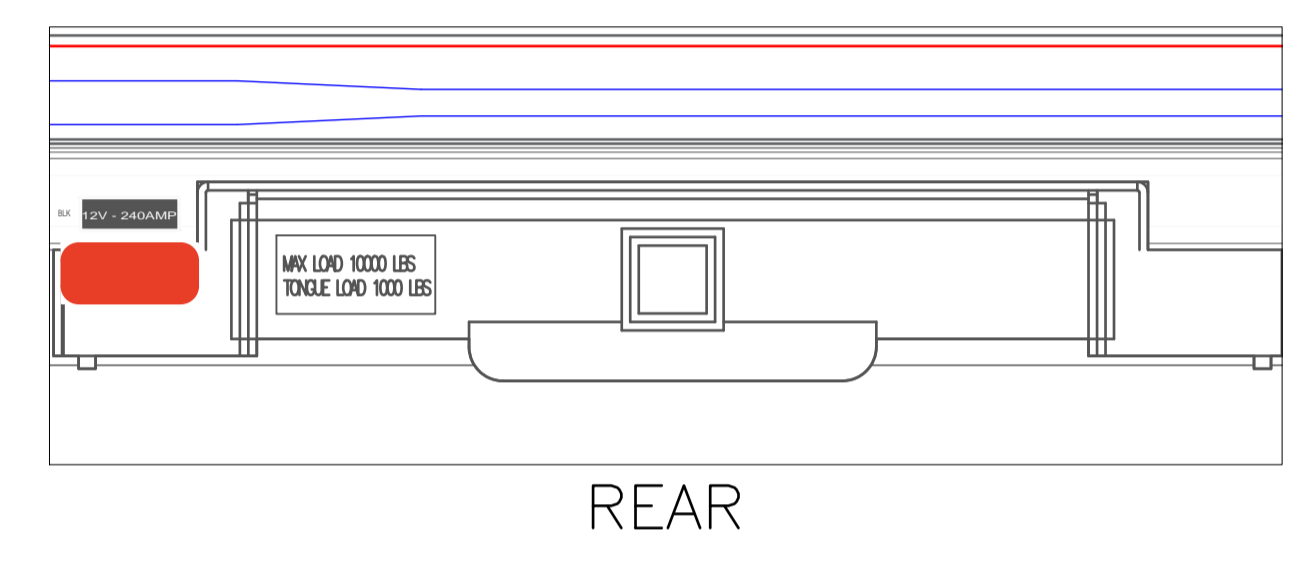

REAR

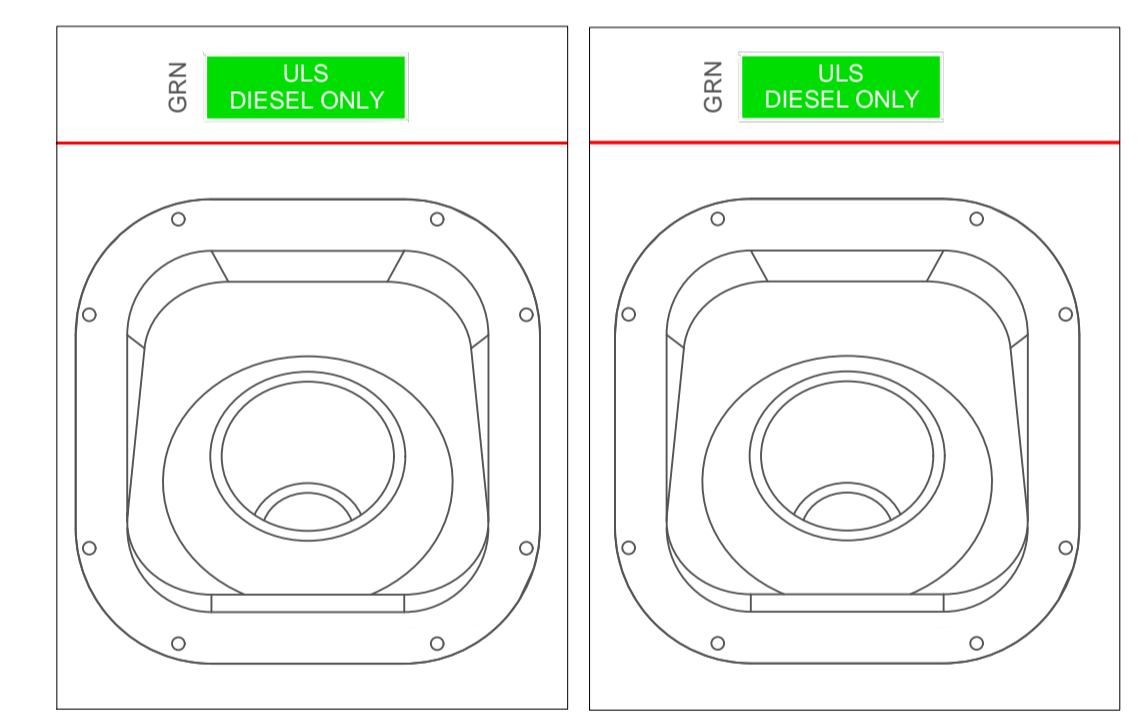

LEFT SIDE

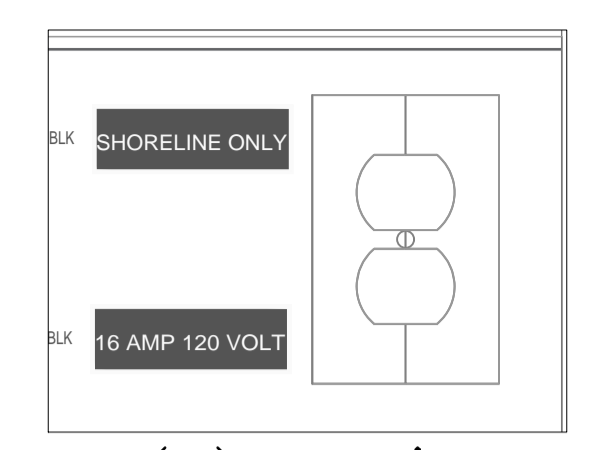

(6) REQ'D CHASSIS CAB & EACH COMPT



REAR

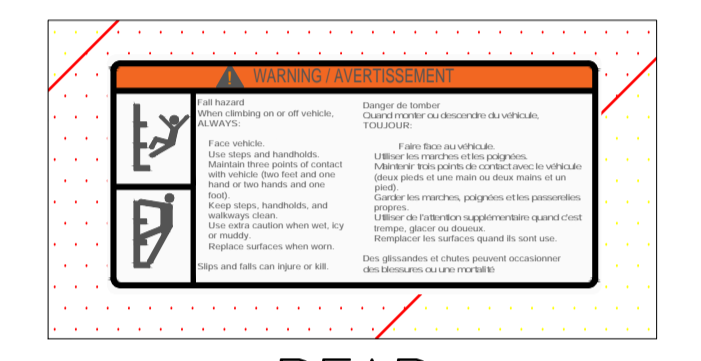

REAR

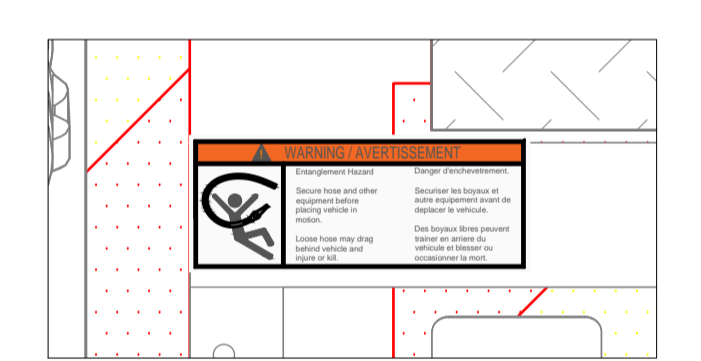

REAR

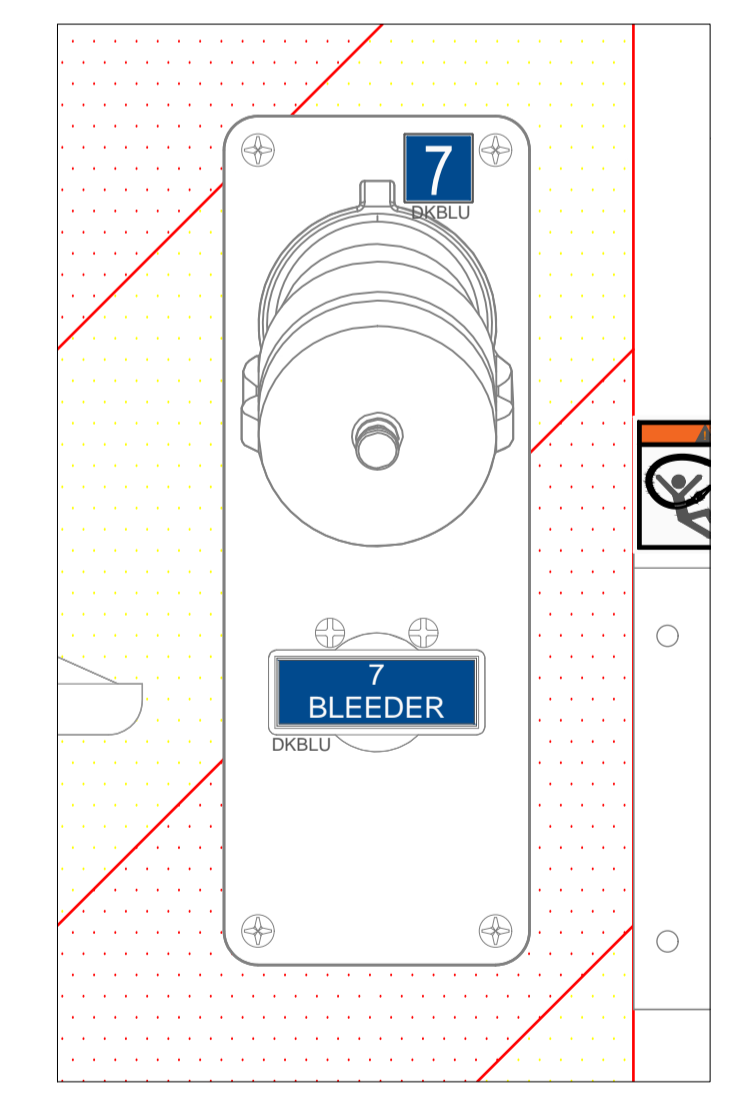

REAR LS

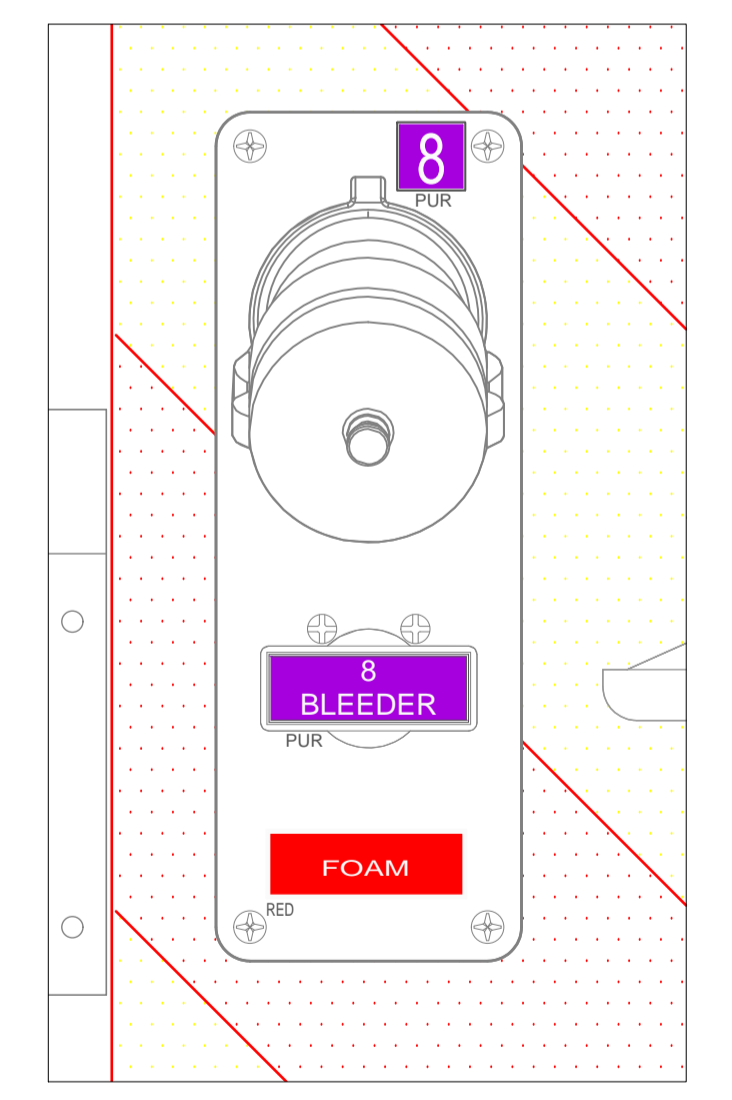

REAR RS

LONG REACH FIRE DEPARTMENT
 JOB No. 22725
 DRAWN BY HDS
 DATE JANUARY 28, 2025
 METALFAB LTD.
 847 CENTRAL ST. CENTREVILLE
 NB. CANADA E7K 2E8

TITLE **OPERATOR'S PANELS**

 DRAWING NO. 22725-19 PG 2 OF 2
 REV 0

REV	DESCRIPTION	BY	DATE
0	FIRST ISSUE		
REVISIONS			

*-COMES WITH CHASSIS -ALL ALUMINUM CONSTRUCTION - ALL DIMENSIONS ARE IN INCHES & APPROXIMATE